

MAINTENANCE INSTRUCTIONS

DINO

160XT II

180XT II

210XT II



Manufacturer:

DINOlift
UP TO THE JOB

Raikkolantie 145

FI-32210 LOIMAA

Tel. +358 20 1772 400

info@dinolift.com

www.dinolift.com

Dealer:



ORIGINAL INSTRUCTIONS

Valid from serial number:

160XT II	17187->
180XT II	30043->
210XT II	3397->

TABLE OF CONTENTS

1.	TO THE MAINTENANCE PERSONNEL	6
1.1.	WARRANTY TERMS.....	7
1.2.	SAFETY AND THE ENVIRONMENT.....	8
1.2.1.	General safety instructions for maintenance	8
1.2.2.	Chemicals	9
1.2.3.	Materials and recyclability.....	9
1.3.	SAFETY MESSAGES	11
2.	SERVICING AND MAINTENANCE	12
2.1.	INSPECTIONS REQUIRED BY AUTHORITIES	14
2.2.	LUBRICATION PLAN	15
3.	ROUTINE MAINTENANCE DURING OPERATION	16
3.1.	DAILY MAINTENANCE TASKS.....	17
3.1.1.	Condition of chassis, boom and work platform	17
3.1.2.	Check the tyres and tyre pressure.....	17
3.1.3.	Check the lights	17
3.1.4.	Check the hydraulic oil.....	17
3.1.5.	Check the hydraulic hoses, pipes and connectors	17
3.1.6.	Check the operation of safety limit switches.....	17
3.1.7.	Check the emergency descent, emergency stop and sound signal	18
3.1.8.	Signs, labels and machine plates	18
3.1.9.	Instruction manuals.....	18
4.	PERIODIC SERVICE	19
4.1.	INSTRUCTIONS FOR MONTHLY SERVICE AND INSPECTION.....	19
4.1.1.	Lubrication of necessary parts.....	19
4.1.2.	Check the slide pads and sliding pad clearances.....	19
4.1.3.	Check the coupling device and overrun.....	20
4.1.4.	Check the driving device.....	20
4.1.5.	Check the condition and fastening of the battery and wiring	21
4.1.6.	Check the levelling system	21
4.2.	INSTRUCTIONS FOR SERVICE AND INSPECTIONS EVERY 6 MONTHS....	22
4.2.1.	Check and lubricate the turning device and gear ring	22
4.2.2.	Lubricate the telescope cylinder bearings	22
4.2.3.	Lubricate the flyer-chain	22
4.2.4.	Check the tyres and tyre pressures	22
4.2.5.	Lubrication of the coupling device and overrun	23
4.2.6.	Brakes.....	23

4.2.7.	Lubrication of the driving device	23
4.2.8.	Check the adjustment of the outreach limit switch RK4.....	24
4.2.9.	Check the load holding and load regulation valves	24
4.3.	INSTRUCTIONS FOR ANNUAL MAINTENANCE AND INSPECTIONS.....	26
4.3.1.	Inspection of chassis structures, boom, platform and platform carrier .	26
4.3.2.	Inspection of support outrigger joints	27
4.3.3.	Inspection of the cylinders and lubrication of cylinder bearings.....	27
4.3.4.	Inspection of the flyer-chains	28
4.3.5.	Inspection of the turning device	29
4.3.6.	Inspection of the rotating adaptor	29
4.3.7.	Inspection of the coupling device and overrun	29
4.3.8.	Jockey wheel slide and threads.....	30
4.3.9.	Inspect the brakes	30
4.3.10.	Inspection of the axle and suspension.....	30
4.3.11.	Inspection of the driving device	30
4.3.12.	Inspection of the lights	30
4.3.13.	Change hydraulic oil and filters.....	31
4.3.14.	Inspection of hydraulic hoses, pipes and connections.....	31
4.3.15.	Inspection of the battery, electrical devices and wiring.....	31
4.3.16.	Measure hydraulic pressures.....	32
4.3.17.	Inspection of the condition and fastening of safety devices.....	32
4.3.18.	Inspection of correct operation of safety devices.....	33
4.3.19.	Testing the outreach- and overload limit switches (RK4 and RK5).....	33
4.3.20.	Inspection of the operating controls on the platform.....	35
4.3.21.	Test loading.....	35
4.3.22.	Inspection of the anti-corrosion treatment	35
4.4.	ADJUSTMENT OF THE MOVEMENT SPEEDS	36
4.5.	ADJUSTMENT OF OUTREACH- AND OVERLOAD LIMIT SWITCHES	39
4.6.	SPECIAL INSPECTION	39
5.	FAULT FINDING	40
5.1.	PROBLEMS WITH POWER SUPPLY	40
5.2.	PROBLEMS WITH MOVEMENTS	42
5.3.	DRIFTING OF BOOM OR OUTRIGGERS	44
5.4.	PROBLEMS WITH TOWING.....	46
6.	HYDRAULIC SYSTEM	48
6.1.	GENERAL INFORMATION OF HYDRAULICS	48
6.2.	HYDRAULIC DIAGRAM.....	48
7.	ELECTRIC SYSTEM	51
7.1.	ELECTRIC COMPONENTS	51
7.2.	ELECTRIC DIAGRAM.....	59

1. TO THE MAINTENANCE PERSONNEL

This maintenance instruction manual is meant to give additional instructions on maintenance, adjustments and repairs of DINO lift to professional maintenance staff familiar with the basic structure and functions of lift.

These maintenance instructions are an addition to the operating instructions accompanying the platform. It is essential, that also the person responsible for the maintenance is familiar with the operating and safety instructions given in the operating instructions manual before working with the platform.



DANGER

Perform all service tasks and repairs according to instructions and health and safety regulations.

Take extra care during all service- and maintenance operations. A faulty machine may cause severe, unforeseen risks.

If you are not certain of the parts, tools or actions please consult your dealer or manufacturer.

Dinolift Oy is constantly developing its products. For this reason, the contents of this manual might not always be in full compliance with the most recent version of the product. Dinolift Oy reserves the right to modify the product without prior notice. Dinolift Oy assumes no liability for any problems caused by changed or missing data or mistakes in this manual.

Please consult your dealer or the manufacturer for more information and detailed instructions.

NOTICE

The operator must be given instructions and consent from the manufacturer for all such specific work methods or operating conditions which the manufacturer has not explicitly defined in operating or maintenance instructions.

The device must neither be altered without the manufacturer's consent nor be used, repaired or tested in a way that does not meet the requirements set by the manufacturer.

1.1. WARRANTY TERMS

- 1§ Dinolift Oy, hereinafter called the Supplier, warrants new aerial work platforms supplied by the company to be free from defects in material and workmanship.
- 2§ The warranty is valid for twelve (12) months from the date of delivery to the customer, or eighteen (18) months at the maximum from the date of delivery from the factory. We will extend our liability for warranty to defects appearing within 3 years in construction (comprising the chassis, outriggers, turning device, boom system, platform and its bearer).
- 3§ The warranty for equipment and parts manufactured by subcontractors is limited to the warranty granted by their respective manufacturers.
- 4§ The warranty only covers parts and components used in the equipment. The warranty does not cover
- (1) damage or loss caused by transportation.
 - (2) damage or loss caused by misconduct, misapplication or accident.
 - (3) damage or loss caused by negligence of instructions, service, maintenance or storage.
 - (4) normal wear of the equipment and damage resulting therefrom, nor wearing parts and material, such as rubber tyres, seals, hoses, fittings, electric equipment, filters, etc.
 - (5) damage or loss caused by maintenance or repair work performed by unauthorised service personnel.
 - (6) damage or loss caused by the purchaser's acts or omissions causing alterations to the quality or structure of the aerial work platforms.
- 5§ No claim will be accepted if non-original parts or parts not approved by the Supplier have been used.
- 6§ All spare parts delivered will be charged from the client at first. Warranty claims should be issued using a form drawn up by the Supplier for this purpose. The form shall be filled in as completely as possible, and sent to the address below within fourteen (14) days from the date of disclosure of the damage:
- Dinolift Oy
After Sales Service
Raikkolantie 145
FI-32210 Loimaa
Finland.
- The charged spare parts will be credited to the client after approval of the warranty claim.
- 7§ The Supplier may choose to
- (1) replace the damaged part
 - (2) repair the damaged part or have it repaired by a subcontractor
 - (3) grant a price reduction. The price reduction is subject to approval by the purchaser.
- 8§ The warranty of replaced or repaired parts expires at the time of expiration of the warranty of the aerial work platform.
- 9§ The purchaser is obliged to send the damaged part to the Supplier for inspection at request. Replaced or refunded parts become the property of the Supplier.

1.2. SAFETY AND THE ENVIRONMENT

1.2.1. General safety instructions for maintenance

Exercise extreme caution in all service, maintenance, troubleshooting and repair works. A faulty device or a device where covers, safety devices or other parts have been removed or disabled, may function in an unexpected way.

If, during maintenance, it is necessary to disable a safety device, make sure that it is returned to use and works correctly before using the device.

Beware of sudden and unexpected movements.

Support the platform, boom system, articulated arms and support outriggers in a position in which the load does not rest on the structure under repair or cause any other danger (e.g. transport position or use of supporting structures)

While removing hydraulic cylinders, note, that

- they may be oily and slippery
- the cylinders are heavy. Use a suitable crane and lifting accessories for lifting.

Do not let oil spill to the ground

Used oils and oily waste must be properly disposed of. Note the national and local recycling and waste policies and regulations.

Remember when handling batteries:

Electrolytic liquid is highly corrosive - Always wear protective clothing and eye wear.

The battery emits an explosive gas while charging - keep away from open flame. Explosion hazard.

Use genuine spare parts. Doing so, you ensure the correct functioning and structural safety even after major repairs.



1.2.2. Chemicals

	Type	Volume
Hydraulic oil	Mobil EAL 32	30 - 35 l
	Kendall Megaflow AW HVI 22	
Hydraulic oil (winter option)	Neste Hydraul 28 Arctic	30 - 35 l
Lubricant	Mobilux EP2 NLGI 2	
	Mobil Grease XHP 222	
Chain lubricant	Würth HHS Grease	
Engine oil (in platforms with power pack)	SAE 10W-30	0,6 l (Honda)
		1,1 l (Hatz)

For more specific engine oil information and recommendations, see the engines' operation manual.

The hydraulic oil used in the device is marked on a fluid level label on the reservoir.

1.2.3. Materials and recyclability

Tyres

Type	Radial M+S	Size	225/70R15C 225/75R16C*
HA-oils (in tread)	Ei	Tyres can be recycled. Note the national and local regulations and policies.	
Zinc (in tread)	N/A		
Cadmium (in tread)	Ei		

*Option

Other materials

Metals	Steel, aluminum, cast iron	Recyclable
	Hydraulic pipes and components	
	Power pack, axles	
Plastics	Covers, mudguards (ABS, PE)	Recyclable
	Tyres	
Battery	Lead battery	Recyclable
Electrical components	Wires, components	Recyclable
Hydraulic hoses		Not recyclable. Hazardous waste.
Oils and lubricants	Used oils, oily filters etc.	Not recyclable. Hazardous waste.

The ability for energy / material recycling depends on local recycling possibilities.

Surface treatment

Primer	zinc rich epoxy (solvent borne)
Surface finish	two pack polyurethane paint

1.3. SAFETY MESSAGES

The following safety alert symbols and safety signal words are used in this manual.

Obey all safety instructions that follow these symbols, in order to avoid dangerous situations and personal injuries.



This is a general safety alert symbol and it is used to alert you to a potential hazard. Obey all safety messages that follow this symbol.



DANGER

Red DANGER-message indicates a hazardous situation which, if not avoided, will result in death or serious injury



WARNING

Orange WARNING -message indicates a hazardous situation which, if not avoided, could result in death or serious injury.



CAUTION

Yellow CAUTION -message indicates a hazardous situation which, if not avoided, could result in minor or moderate injury.

NOTICE

Blue notice-message is used to bring your attention to special notifications or instructions relating to operation or maintenance of the lift. These messages include instructions to avoid property damages and material losses or to increase reliability and safe operation of the lift.

2. SERVICING AND MAINTENANCE

Maint.	Schedule	Person responsible	Reference
A	Daily	Operator	Operating instructions
B	1 month / 100 hours*	Competent person who is familiar with the lift	Maintenance instructions
C	6 months / 400 hours*	Competent person who is familiar with the lift	Maintenance instructions
D	Annually / 800 hours*	Skilled technician who is well familiar with the structure and operation of the lift	Maintenance instructions
E	As needed	Skilled technician who is well familiar with the structure and operation of the lift	Maintenance instructions

* Service must be performed every indicated month or operating hour interval, whichever comes first.

NOTICE

In addition to daily maintenance, every user must do a worksite inspection before operating the lift.

C = Check (general checking of condition).

I = Thorough Inspection. Performed according to separate procedure described in maintenance instructions.

G = Grease

D = Do the replacements, repairs or other maintenance tasks described in the instructions

	Maintenance item	A	B	C	D	E
1	Condition of chassis structures, boom and work platform	C	C	C	I	
2	Bearings of the overload protection device joint		G	C/G	C/G	
3	Bearings of outriggers and outrigger cylinders		G	C/G	I/G	
4	Bearings of outrigger footplates and moving parts of outrigger limit switch system		G	C/G	I/G	
5	Bearings of boom and articulated arms		G	C/G	C/G	
6	Bearings of the platform		G	C/G	C/G	
7	Bearings of the levelling cylinders		G	C/G	C/G	
8	Bearings of the lifting cylinder		G	C/G	C/G	
9	Sliding surfaces / rolls of the telescope		C/G	C/G	C/G	
10	Bearings of the telescope cylinder			C/G	C/G	
11	Condition of cylinders				I	
12	Flyer-chain			G	I/G	
13	Slide pads and sliding pad clearances		C	C	C	
14	Turning device			G	I/G	
15	Electro-hydraulic rotating adaptor				C	
16	Tyres and tyre pressures	C	C	I	I	
17	Coupling / overrun device		C	G	I/G	
18	Jockey wheel slide and threads				I/G	
19	Brakes			C	C	

	Maintenance item	A	B	C	D	E
20	Axles and suspension				I	
21	Driving device		C	G	I	
22	Lights	C	C	C	I	
23	Hydraulic oil	C	C	C	D	
24	Hydraulic hoses, pipes and fittings	C	C	C	I	
25	Condition and attachment of battery, electrical devices and wiring		C	C	I	
26	Hydraulic pressure				I	
27	Condition of safety limit switches				C	
28	Operation of safety limit switches	C	C	C	I	
29	Operation of overload protection device			C	I	D
30	Load holding and load regulation valves			C	C	
31	Platform levelling system		C	C	C	
32	Platform control devices	C			I	
33	Emergency descend, emergency stop and sound signal	C	C	C	C	
34	Signs, labels and machine plates	C	C	C	C	
35	Instruction manuals	C	C	C	C	
36	Test loading				I	
37	Corrosion protection				C	D
38	Movement speed adjustment					D
39	Special inspection					D

Always lubricate the lift and apply a protective grease film immediately after the washing.

Special inspection is required if the lift has been damaged in a manner which may affect its load-bearing capacity or safe operation. For further instructions, see the maintenance instructions manual.

NOTICE

If the platform has a combustion engine power pack, check the engine manual for information on maintenance procedures required by the engine.

NOTICE

If the lift is operated under demanding conditions (in exceptionally humid or dusty environment, corrosive climate, etc.), the intervals between the oil changes and the other inspections shall be shortened to meet the prevailing conditions in order to maintain the operational safety and reliability of the lift.

2.1. INSPECTIONS REQUIRED BY AUTHORITIES

Inspections must be performed in accordance with local, state or federal regulations, legislation, directives, standards. The manufacturer recommends following inspections, as required by local authorities in platforms country of origin.

A pre-use inspection must be done before taking the platform to use for the first time and before first start-up after major repairs and alterations.

A thorough inspection and a test loading of the lift must be carried out at least once every twelve (12) months.

The platform should undergo a major inspection within ten (10) years after having been originally put into service. A major inspection includes non-destructive testing and inspection while dis-assembled.

A special inspection should be done if the platform has been exposed to exceptional circumstances which may have affected the structural integrity of critical components.

The inspections should be carried out on regular basis throughout the service life of the lift. If the lift is used under extreme conditions, intervals between the inspections shall be reduced.

The overall operating condition of the lift as well as the condition of the safety-related control devices shall be established in the regular inspections. Particular attention shall be paid to changes which affect the operational safety.

During inspections the notifications given in previous inspections, practical experience from use and information on performed repairs should be taken into account and can be implemented for better safety.

Major and special inspections shall be carried out by a competent person or competent body, who is familiar with the operation and structure of the lift. The competent person should periodically update their knowledge and be able to demonstrate their competency if so required.

A report should be made of the inspections and the reports should be kept with the unit stored in the space reserved for it.

NOTICE

Always check the local, state or federal regulations about aerial platform inspections and inspector qualifications from local authorities.

2.2. LUBRICATION PLAN

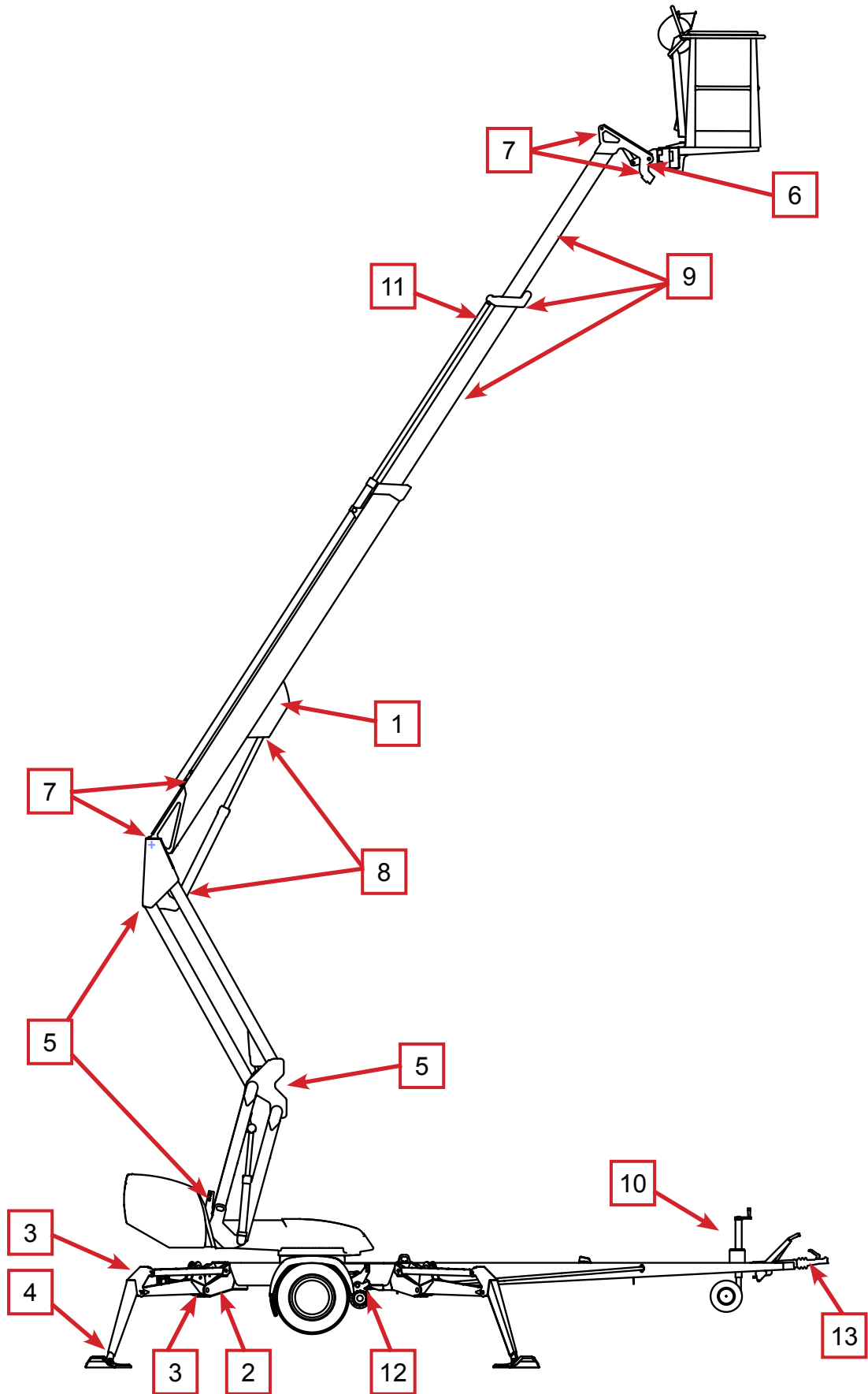

3. ROUTINE MAINTENANCE DURING OPERATION

This chapter describes the service and maintenance operations that the operator of the platform is responsible for.

Other maintenance operations require special training, tools and materials or specific measurements and adjustment values. They are separately described in maintenance instructions manual. Please contact your maintenance partner, dealer or manufacturer.

Make sure that all service and maintenance procedures are performed in time and according to instructions.

 WARNING	Any faults which may affect the operational safety of the unit must be repaired before the lift is used for the next time
--	---

Keep the lift clean. Clean the lift carefully before any service and maintenance operations or inspections. Impurities may cause serious problems in for example in the hydraulic system.

Use original spare parts and service kits. See spare part list for detailed information on spare parts.

The first service after 20 hours of operation

- change the pressure filter element
- adjust the brakes according to the instructions (see point “Wheel brakes and bearings”)
- check the wheel bolts for tightness after about 100 km of driving

If the lift is operated under demanding conditions (in exceptionally humid or dusty environment, corrosive climate, etc.), the intervals between the oil changes and the other inspections shall be shortened to meet the prevailing conditions in order to maintain the operational safety and reliability of the lift.

The performance of the periodic servicing and the inspections is absolutely mandatory, because their negligence may impair the operational safety of the lift.

The guarantee will not remain valid, if the servicing and the periodic inspections are not performed.

3.1. DAILY MAINTENANCE TASKS

3.1.1. Condition of chassis, boom and work platform

Inspect visually the condition of access systems, work platform, platform gate and handrails. Check that the chassis and boom have no visible signs of structural damage.

3.1.2. Check the tyres and tyre pressure

Inspect the condition of tyres visually and check that they are not flat.

3.1.3. Check the lights

Check all the warning and signal lights and trailer lights for road traffic.

3.1.4. Check the hydraulic oil

Check the hydraulic oil level while the platform is in transport position. Add oil if needed.

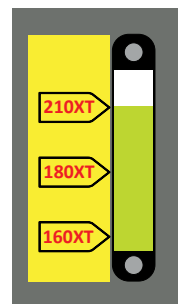
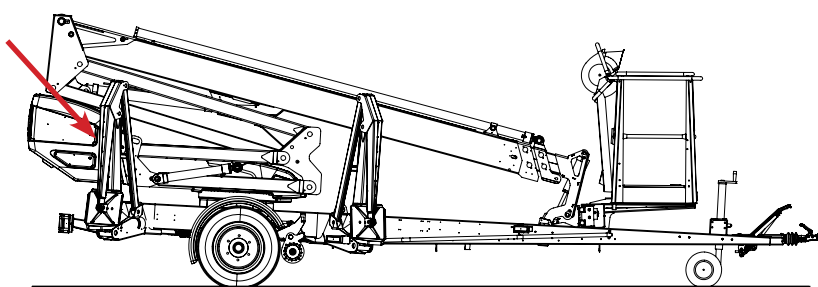

The oil tank is located under a cover on the right side of the device.

Check that the oil visible from the oil meter looks clean and normal (no excess foam etc.)

3.1.5. Check the hydraulic hoses, pipes and connectors

Inspect the condition of hydraulic hoses, pipes and connections visually. Make sure that there are no visible oil leaks.

Any externally damaged hoses or clashed pipes and connections must be changed.

3.1.6. Check the operation of safety limit switches

Test the correct operation of safety limit switches that prevent the boom and outrigger movements unless the platform is in a correct position.

1. Platform must be in transport position, outriggers up and the driving device connected.
2. Lift the boom from lower controls.
The boom must not work in any position of the control device.
3. Drive the outriggers down to operating position
4. Lift the boom so that the boom is not on the support
5. Drive the outriggers.
The outriggers must not work in any position of the control device.

3.1.7. Check the emergency descent, emergency stop and sound signal

Test the correct operation of emergency stop, emergency descent system and the sound signal from the lower controls and platform controls.

- lift the boom up approximately 1-2 meters and drive the telescope out 1-2 meters. While driving the movement, push down the emergency stop button. The movement should stop.
- Drive the telescope in and lower the boom by using emergency descent
- lift up the emergency stop button
- test the sound signal

3.1.8. Signs, labels and machine plates

Make sure, that all the plates, adhesive tapes and instructional labels on control stations are intact, clean and legible.

If the labels have started to come off or tear apart or if the symbols or texts are illegible the labels must be replaced.

Product numbers of labels are marked on the labels or they can be found in the spare part lists.

3.1.9. Instruction manuals

Check that the instruction manuals accompanying the platform are correctly stored on the platform and that they are legible.

4. PERIODIC SERVICE

Periodic service shall be done according to these instructions. These maintenance and service procedures shall be performed by competent maintenance personnel.

4.1. INSTRUCTIONS FOR MONTHLY SERVICE AND INSPECTION

Always do all daily inspections in addition to monthly service tasks.
If you notice any flaws, defects or damage to the lift, take necessary corrective action.
It is strictly prohibited to use a lift which is out of order.

4.1.1. Lubrication of necessary parts

Maintenance items 2-9. Grease nipple positions are shown in the lubrication plan and they are marked with labels on the lift.

Add new lubricant until the grease coming out of the joint is clean. Wipe off excess grease if necessary.

Lubricant: Esso Beacon EP2 or equivalent.

Sliding surfaces of the telescope are lubricated with silicone.

	Number in lubrication plan
Bearings of the safety device	1
Bearings of the outriggers and outrigger cylinders	2 ja 3
Bearings of the outrigger foot plates	4
Bearings of the boom and the articulated arms	5
Bearings of the platform	6
Bearings of the levelling cylinders	7
Bearings of the lifting cylinder	8
Sliding surfaces/rolls of the telescope	9

NOTICE

The overload protection device joint (point 1) must absolutely be lubricated regularly and always immediately after the lift has been washed.

4.1.2. Check the slide pads and sliding pad clearances

Check the clearance between the slide pads and sliding surfaces and adjust the pads if necessary. The pads should be adjusted so that the boom extensions are centered and do not scrape to the edges. The clearance between slide pad and sliding surface must be minimal but the pads should not squeeze the boom extension.

NOTICE

When adjusting slide pads, they must be secured with threadlocker.

4.1.3. Check the coupling device and overrun

Check the condition of the coupling device and the overrun device. Check the brakes.

Adjusting the brakes

1. Support the lift by raising its wheels off the ground.
2. Make sure that the wheels can rotate freely.
3. Check the attachment of the brake rods.
4. Turn the adjustment wheel, behind the hole marked by the arrow, until the wheel no longer can be turned by hand.



5. Turn the bolt counter-clockwise until the wheel can be turned freely.
6. Once the hand brake has been released, and the operating brakes adjusted, the springs on the brake rod extension must be pre-tightened as shown in the picture.

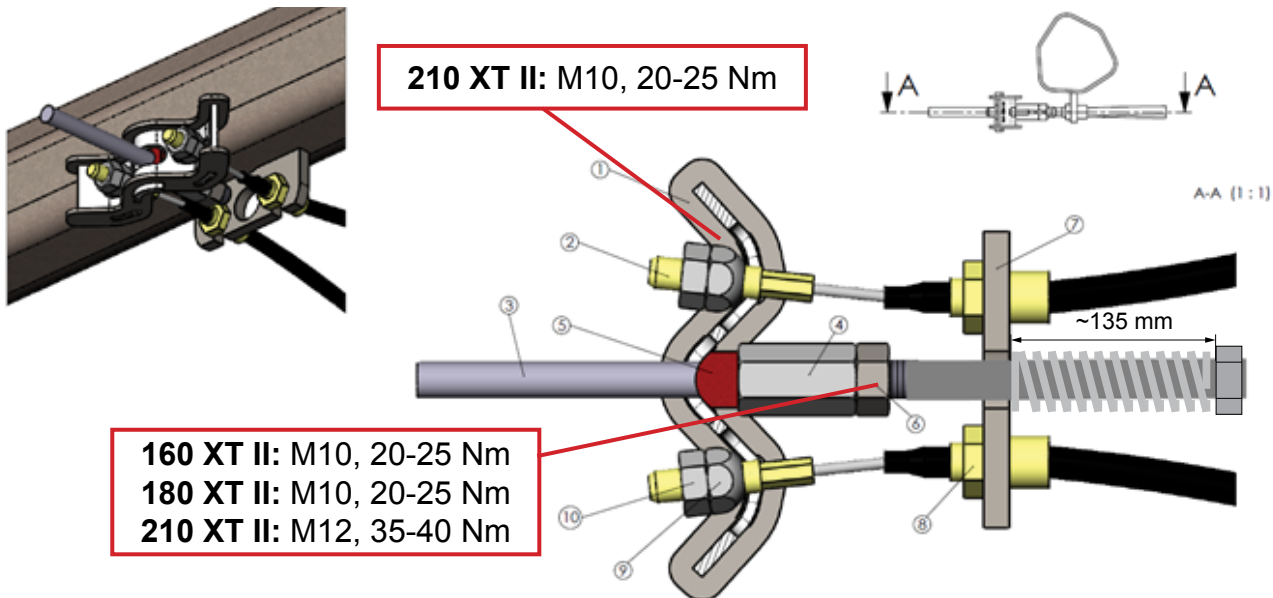

If you tighten the brake system too much, the brakes will overheat during transportation, and the the driving device will require more force.

We recommend performing a test run after the adjustment in order to ensure flawless operation of the brakes by braking 2-3 times.

NOTICE

The brakes must be adjusted after every 5000 km. Depending on the total towing distance of the trailer, the adjustment may not be necessary at every monthly service.

4.1.4. Check the driving device

Check that the driving device functions correctly. The platform must travel in a straight line when driving straight.

Check that the load holding valves in the driving device hold.

4.1.5. Check the condition and fastening of the battery and wiring

Check the condition and correct fastening of the battery. Perform visual inspection of all electric wiring.

4.1.6. Check the levelling system

A so-called Slave Cylinder System is applied for levelling of the platform. The slave cylinder under the platform is controlled by a master cylinder.

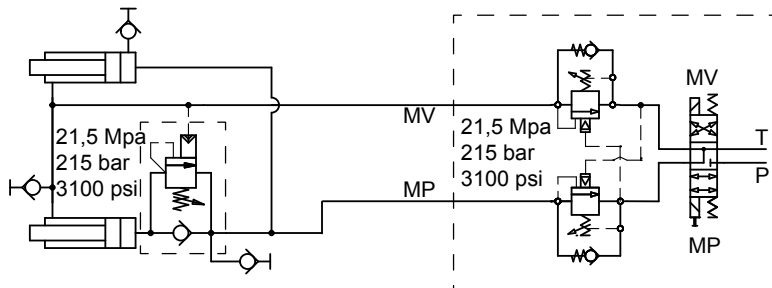

The platform keeps its level position only if the valves in the system are tight.

The levelling system comprises of the following parts:

1. Master cylinder
2. Slave cylinder
3. Load regulation valve
4. Double load regulation valve (8A and 8B)
5. Electric directional valve

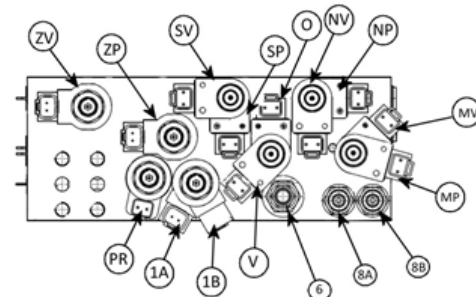

If the platform, viewed by the operator, drifts forwards, the reason can be:

- a leak in the slave cylinder double load regulation valve (on the piston rod side) in the direction of the electric directional valve (which is not tight)
- an internal leakage in the cylinder

If the platform, viewed by the operator, drifts backwards, the reason can be:

- a leak in the load regulation valve (3) on the piston (bottom) side of the slave cylinder in the direction of the electric directional valve (5) (which is not tight)
- an internal leakage in the cylinder

The leak will cause drifting of the platform until the load regulation valve (23) under the platform is closed. The closing is caused by dropping of the pressure on the piston rod side to the opening ratio, which is 5:1

Air in the levelling system causes inaccuracy during levelling of the platform.

If the valves are not tight, refer to the service instructions for checking the load regulation valves.

Settings of the load regulation valves:

- opening pressure of the double load regulation valves (4) is 21,5 MPa (215 bar)
- opening pressure of the load regulation valve (3) under the platform is 21.5 MPa (215 bar)

Do not change the preset values.

4.2. INSTRUCTIONS FOR SERVICE AND INSPECTIONS EVERY 6 MONTHS

These service measures must be done between annual service at every 6 months or 400 hours, whichever comes first.

Always do all daily inspections and monthly service measures in addition to the service tasks described here.

4.2.1. Check and lubricate the turning device and gear ring

Perform overall visual inspection of the turning device and its weldings. Check especially the attachment of joints and angular gear.

Lubricate the turning device bearings and gear ring (4 nipples).
Number 14 in lubrication plan.

1. Remove the crescent-shaped covers from the underside of the lift.
2. Lubricate the turning bearing nipples (4 pieces).
3. Put the covers back.

NOTICE

Excess grease pressure may press out the turning bearing seal.

4.2.2. Lubricate the telescope cylinder bearings

Add new lubricant until the grease coming out of the joint is clean. Wipe off excess grease if necessary.

Lubricant: Esso Beacon EP2 or equivalent.

Number 11 in lubrication plan.

4.2.3. Lubricate the flyer-chain

Lubricate the visible parts of the Flyer-chains for the boom twice a year. Use Master chain lubricant 1-4014 or equivalent.

4.2.4. Check the tyres and tyre pressures

Check the wheel bolts and tyre pressures.

Wheel bolts:

160XT II = 90 Nm

180XT II, 210XT II = 325 Nm

Tyre pressures:

- On the rear axle 450 kPa (4,5 bar)
- On the tow-bar jockey wheel 250 kPa (2,5 bar)



4.2.5. Lubrication of the coupling device and overrun

Number 13 in lubrication plan.

If necessary, apply a thin grease film on the moving parts of the ball-coupling

4.2.6. Brakes

The following procedures must be done every 13,000 - 15,000 km or every six months:

- check the brake linings for wear
- check the operation of the overrun brake
- lubricate the sliding parts of the overrun brake

The wheel bearings are lubricated for life and do not require any service.

(The bearings do not need any additional lubrication, and they neither need nor can be re-adjusted.)

Turn the wheels at least once every 3 months to keep the lubricating film intact.

NOTICE

The service-life of the double row angular contact compact bearings is long and they are maintenance-free. Therefore, the bearings very rarely break under normal operating conditions. If a bearing failure, due to exceptional operating conditions, occurs, replace the entire brake drum assembly with the pressed-in bearings and locking nut.

Assign a specialized workshop for the work.

4.2.7. Lubrication of the driving device

Number 12 in lubrication plan.

4.2.8. Check the adjustment of the outreach limit switch RK4

To check the correct adjustment of the outreach limit switch RK4:

1. Put a carefully weighed test load on the platform according to the picture:
 - 160XT II: w = 270 kg
 - 180XT II: w = 215 kg
 - 210XT II: w = 80 kg
2. Drive the boom to a horizontal position from the chassis control panel.
3. Extend the telescope until it stops and a red light starts flashing.
4. Measure the stroke and compare it to the values given in the picture.
5. If the stroke is too long, it must be readjusted.

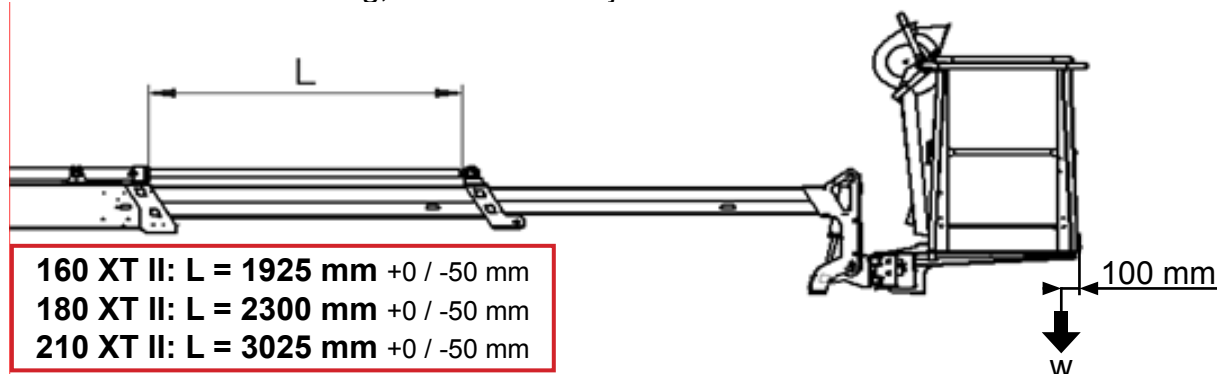

4.2.9. Check the load holding and load regulation valves

Check the operation of load holding and load regulation valves as follows. If a valve is leaking, do the necessary service actions.

1. Outrigger load holding valves
 - lift the platform to operating position on a level surface
 - measure the distance from the chassis to the floor separately at each outrigger
 - After a few minutes, measure the height again. It should be the same as before.
2. Load regulation valves on the boom cylinder and the cylinders of the articulated arms:
 - Drive the boom to a position in which its movement can be reliably measured.
 - Observe the possible movement of the boom in a few minute's time.
 - Do the measurement again. It should be the same as before.
3. load regulation valve on the telescope cylinder
 - extend the telescope and stop the movement at any position
 - measure the stroke
 - lift the boom closer to a horizontal position and observe in a few minutes .
 - lower the boom and do the measurement again. It should be the same as before.
4. load regulation valve on the platform levelling system
 - Put a load of 100 - 200 kg on the platform
 - Measure the distance from the rear edge of the platform to the floor
 - Observe for a few minutes
 - Do the measurement again. It should be the same as before.

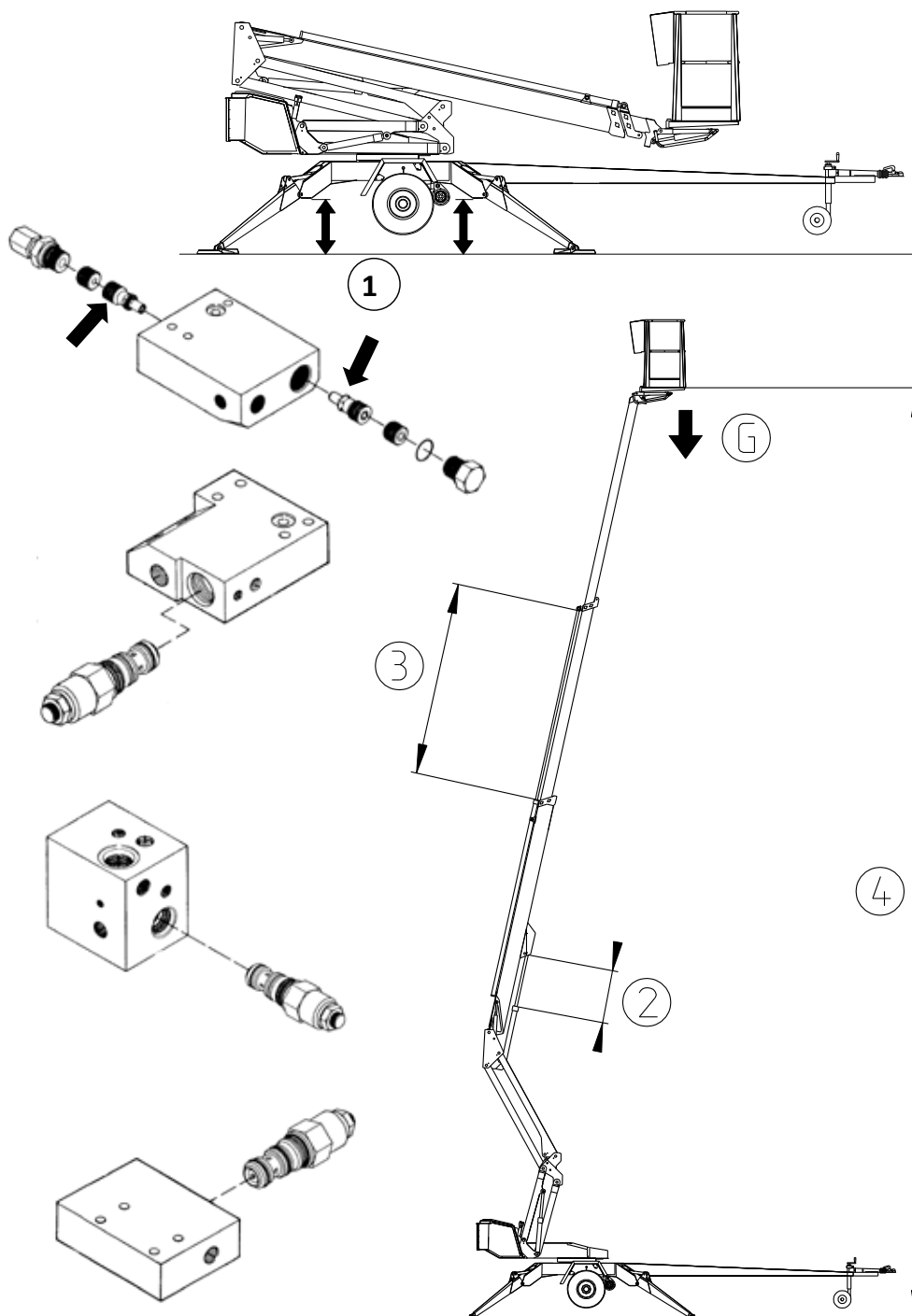

Service instructions

1. Disconnect and clean the valve
2. Check the O-rings and replace, if necessary
3. Put the valves carefully in place
4. Replace the valve, if necessary

 - Do not change the settings of the valves.

NOTICE

The valve can only be opened 2-3 times before it has to be replaced. Otherwise it may start to leak.

WARNING

Support the platform, boom system, articulated arm and outriggers in a position, where the load does not rest on the structure under repair. Make sure to relieve the residual pressure from the cylinders

4.3. INSTRUCTIONS FOR ANNUAL MAINTENANCE AND INSPECTIONS

Annual servicing must be done every 12 months or 800 hours of operation, whichever comes first. This list contains all annual maintenance tasks and inspections. Daily, monthly or 6 month services are not needed in addition.

Under demanding conditions where moisture, corrosive substances or corrosive climate may speed up the deterioration of the structure and induce malfunctions, the inspection must be performed more often and the influence of corrosion and malfunctions must be reduced by using appropriate protective means.

Only technical specialists who are familiar with the structure and the operation of the lift are allowed to maintain the lift. We recommend turning to the service staff of the dealer.

NOTICE

Annual servicing and inspections included in it do not replace the annual inspection by a competent person or competent body that may be required by national authorities.

Clean the lift thoroughly before the service

The hydraulic and electric appliances must not be dismantled if they are not clean. Any contaminants in the system may cause malfunctions later on. Wash the lift externally.

- use pressurized air to dry the electric devices, hydraulic connectors etc. before opening them
- apply appropriate moisture repellent to the electric appliances after the drying
- always protect the piston rods with e.g. CRC3-36 anti-corrosive agent after washing with a solvent



CAUTION

Be careful not to direct the high pressure water jet straight to the electric appliances, such as the control panels on the chassis and on the platform, relays, solenoid valves and limit switches.

4.3.1. Inspection of chassis structures, boom, platform and platform carrier

Check the condition of the chassis

- general condition
- check the attachment of the tow-bar to the chassis
- check the condition of the overrun and its attachment to the chassis.
- check the rims, the tightness of the wheel bolts, the tyres and the tyre pressure
- check the condition of the transport support of the boom

Inspect the boom

- extend the telescope and check that there are no permanent deformations, dents or traces of substantial wear in the boom
- also check the welded seams for wear, cracks or breaches

- check the boom attachment for cracks or breaches
- check the play and attachment of the gliding surfaces on the boom and adjust the pads if necessary. Lubricate the sliding surfaces.
- check the condition of the cable chain, its clamp brackets as well as the tightness of the screw connections
- check the condition of the platform brackets
- check the locking of the platform pin

Inspect the platform

- general condition
- check that the platform does not show signs of deformations, substantial wear or buckles
- check that the handrails, the steps, the gate and the attachment of the gate are in order
- check that the lock of the gate and the gas spring are in order
- check the condition of the platform floor plate
- check the platform carrier for notable buckles or deformations

4.3.2. Inspection of support outrigger joints

Check the mechanical structure of the outriggers and the welded seams

The structures must not show signs of deformations or cracks. No fractures or cracks are allowed in the welded seams.

Check the footplates for deformations, cracks or breaches.
Also check that the footplate can turn freely on its joint.

Check the condition of the joints:

1. lower the outriggers slightly
2. swing the outriggers back and forth in the horizontal plane and check the joints for play
3. check the operation and condition of the limit switch mechanisms on the outriggers
4. replace any worn out parts
5. lubricate the joints (refer to the lubrication plan)

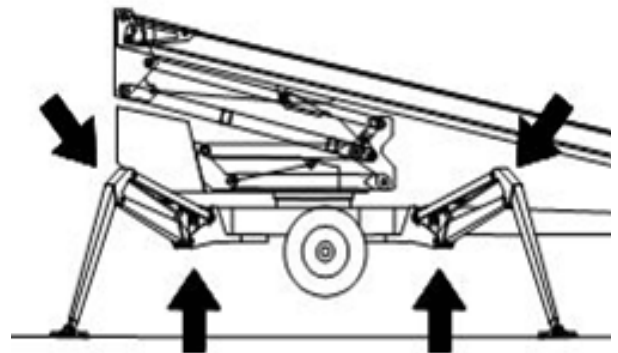

Lower the outriggers to support position.

4.3.3. Inspection of the cylinders and lubrication of cylinder bearings

1. Lift cylinder:
 - drive the lift cylinder to its upper position from the chassis control panel
 - inspect the condition of the piston rod and tightness of the connections
 - drive the lift cylinder to its lower position from the chassis control panel and inspect the connections for tightness
2. Telescope cylinder:
 - retract and extend the telescope cylinder from the chassis control panel
 - inspect the condition and tightness of the cylinder
 - check the condition of the cylinder, piston rod and the wiper ring of the cylinder and inspect the connections for tightness

3. Lubricate the joints of the lifting, telescope and levelling cylinders
4. Check the condition of the slave cylinder guard
5. Articulated arm cylinders
 - extend the articulated arm cylinders from the lower control panel
 - check the condition of the cylinder, piston rod and the wiper ring of the cylinder and inspect the connections for tightness
6. Outrigger cylinders
 - drive the outriggers to operating position
 - check the condition of the cylinder, piston rod and the wiper ring of the cylinder and inspect the connections for tightness
 - lubricate the joints
 - check the condition of the support outrigger cylinder guards

4.3.4. Inspection of the flyer-chains

Check the condition, locking and adjustment of the Flyer-chains.

1. Drive the boom to a level position.
2. Extend the boom extensions completely and retract it about 30 mm.
3. Check that the extending chain closer to the limit switch (B) does not hang notably. Adjust as necessary. **Note Tightening this chain also affects the length of the spring (point 5).**
4. Check that the extending chain farther from the limit switch (A) hangs about 35 mm at the middle. Adjust as necessary.
5. Check the length of the spring of the retracting chain (C). The length of the spring should be about 32mm.
6. Finally, check that the distance between the limit switch is about 6mm.

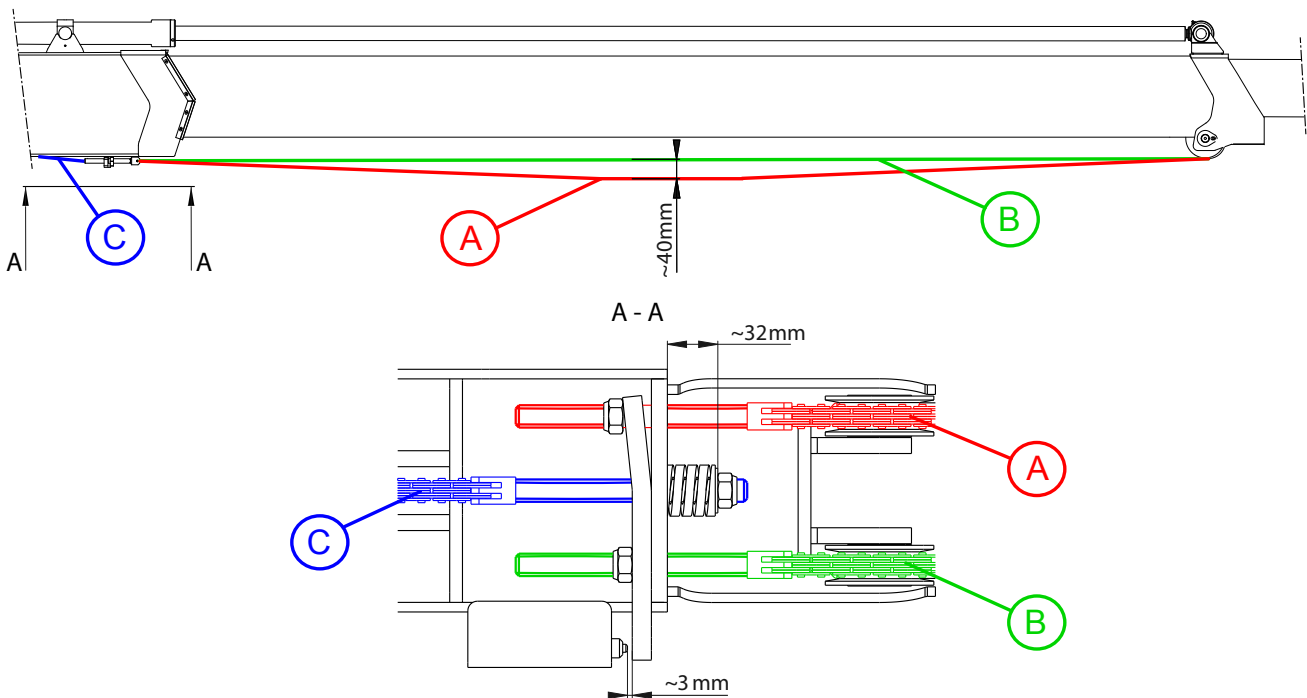

7. Extend and retract the boom extensions several times after the readjustment. Return the boom extensions to the measuring position, and repeat the measurement.
8. Check the attachment of the unloaded chain (A) by pulling it with your hand

4.3.5. Inspection of the turning device

Perform overall visual inspection of the turning device and its weldings. Check especially the attachment of joints and angular gear.

Inspect the turning device

- general condition
- check the play and attachment of the angular gear
- check the condition of the gear ring
- check the turning bearing play. Max. allowed axial play is about 1 mm.
- check the attachment of the turning motor
- check the tightening torque of the turning bearing's attachment screws:

M16: 280 Nm
M12: 115 Nm

NOTICE

If you have to turn open or tighten the attachment bolts, secure them with threadlocker. Always tighten the bolts crosswise.

Lubricate the turning device bearings and gear ring. Number 14 in lubrication plan.

1. Remove the crescent-shaped covers from the underside of the lift.
2. Lubricate the turning bearing nipples (4 pieces).
3. Put the covers back.

NOTICE

Excess grease pressure may press out the turning bearing seal.

4.3.6. Inspection of the rotating adaptor

Lift the articulated arms up so that you can remove the turning device covers.

check the electro-hydraulic rotating adaptor for leaks. Check that the lever arm neither seizes nor is loose.

After the inspection, put the covers back in place.

4.3.7. Inspection of the coupling device and overrun

Check:

- the attachment of the overrun
- clearance
- condition of the towball-coupling
- condition of the locking device
- that the overrun brake mechanism moves freely

4.3.8. Jockey wheel slide and threads

Lubricate the jockey wheel slide and threads.
Number 10 in lubrication plan.

4.3.9. Inspect the brakes

1. remove the wheels
2. clean the brake system and check the settings
3. check that the brake shoes can move, and that their springs properly return them
4. replace any worn out linings
5. check the condition of the driving device and lubricate the joints
6. put the wheels in place and tighten the wheel bolts: Tightening torque: 325 Nm

Remember to re-check the tightness of the wheel bolts after a drive of about 100 km.

7. check the tyre pressures: Rear axle 450 kPa (4,5 bar)
Tow-bar jockey wheel 250 kPa (2,5 bar)
8. check the free movement of the overrun brake and the parking brake
9. check the safety wires

4.3.10. Inspection of the axle and suspension

- check the attachment of the axle
- check the condition of the rubber absorbers and the torsion arms

4.3.11. Inspection of the driving device

Check that the valves of the driving device operate properly and no movement occurs when the spools are in the neutral position.

4.3.12. Inspection of the lights

Check the condition of the lights and the reflectors. Replace broken lights, bulbs and reflectors.

4.3.13. Change hydraulic oil and filters



CAUTION

Protect your skin against the hydraulic oil. Used oils can be harmful to the skin.

To change oil and filters:

1. drain the oil tank through the draining plug opening, with all cylinders in retracted position
2. clean and rinse the oil tank with suitable agent
3. replace the pressure filters
 1. install the drain plug
 2. refill the tank with fresh oil, the oil volume required for change is about 20 liters
 - information on factory filling oil is marked in the label on the oil tank.
 - The viscosity class of the hydraulic oil must be ISO VG 32 and the oil must meet the requirements according to DIN 51524- HLP.
3. if required, top up hydraulic oil to the upper level marking of the level eye while the lift is in the transport position

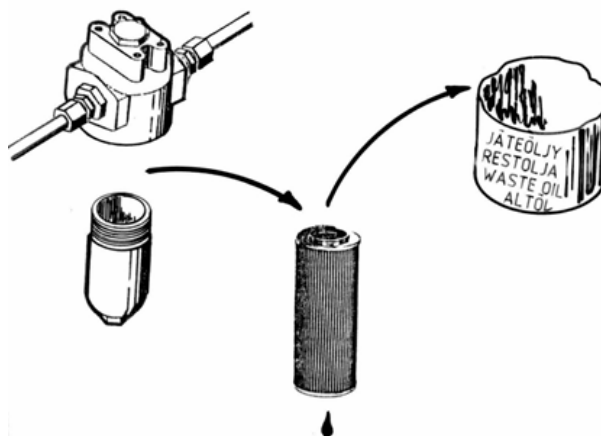

NOTICE

Do not mix different oils types.

4.3.14. Inspection of hydraulic hoses, pipes and connections

- Check the hoses for leaks and chafing
- Check that there are no dents, leaks, trace of corrosion or chafing at the clamps
- Check that the pipes are properly fastened
- Check the hose and pipe connections for leaks

Replace any externally damaged hoses or clashed pipes.

4.3.15. Inspection of the battery, electrical devices and wiring

Thorough inspection of the electric system

- check that the control panel boxes are dry, clean and tight.
- check the condition of the cable connections and their protection against moisture
- check the condition and attachment of the limit switches
- check the limit switch lead-throughs for tightness
- check the connections of the electric valves
- check the connections of the solenoid valves
- perform visual inspection of all electric wiring

- check the condition of the mains cable plug
- check the condition of the electric motor

4.3.16. Measure hydraulic pressures

1. connect the pressure gauge to the measuring point (MP)

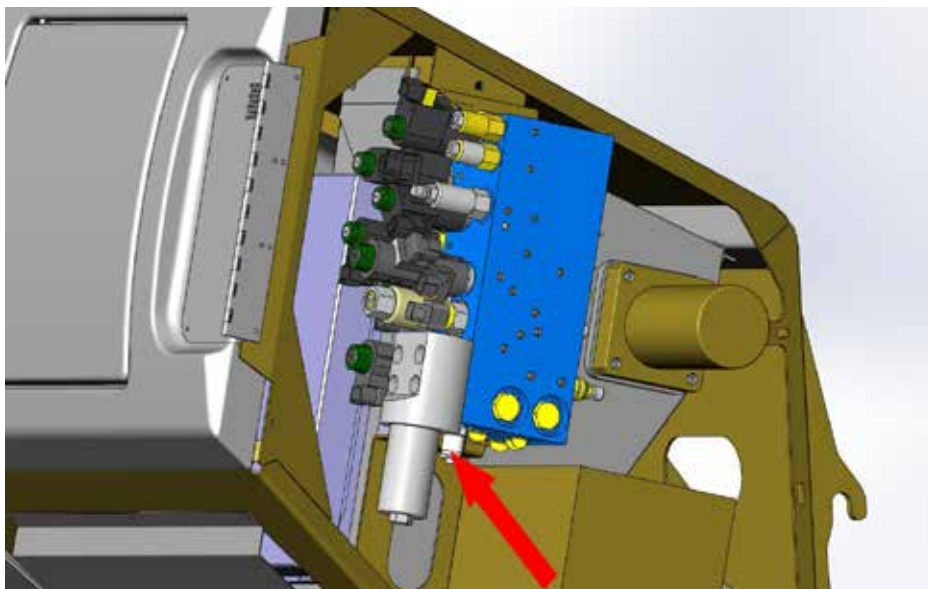

2. make the oil flow through the relief valve by driving one of the movements against the end stop
3. read the pressure from the gauge
max. pressure with warm oil (40–60 °C): 20–21,5 MPa (200–215 bar)
turning pressure 5,5-7,0 MPa (55-70 bar)

if you have to readjust the pressure setting, secure the new setting with a seal.

4.3.17. Inspection of the condition and fastening of safety devices

Check the attachment and the external condition of the limit switches

- from the tow-bar (transport position of the platform, RK3)
- safety device (RK4 and RK5)
- support outriggers (RK11, RK12, RK13 and RK14)
- boom (RK7 and RK8)

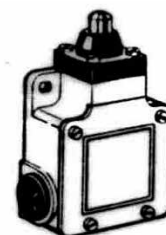

4.3.18. Inspection of correct operation of safety devices

Check the operation of the safety devices operated from the chassis control panel:

1. Lift the platform up from the boom support
 - support outriggers must not work
2. Lower the boom to boom support and lift the outriggers
 - the boom must not operate
3. lower the outriggers (level the lift to operating position)
4. put a test load onto the work platform according to the picture:

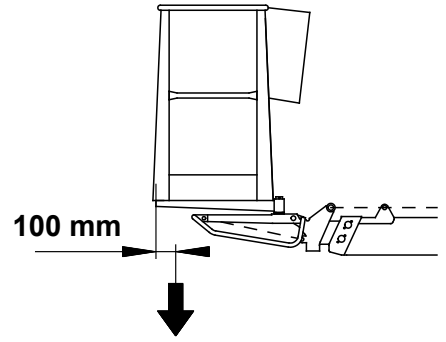

- 160XT II: w = 270 kg
- 180XT II: w = 215 kg
- 210XT II: w = 80 kg

5. lift the boom and extend the telescope
 - The movement stops and the red outreach limit signal light lights up (at max. outreach). Now:
 lifting of the boom should be operational - the lowering must NOT be operational
 retraction of the telescope should be operational - the extension must NOT be operational

4.3.19. Testing the outreach- and overload limit switches (RK4 and RK5)

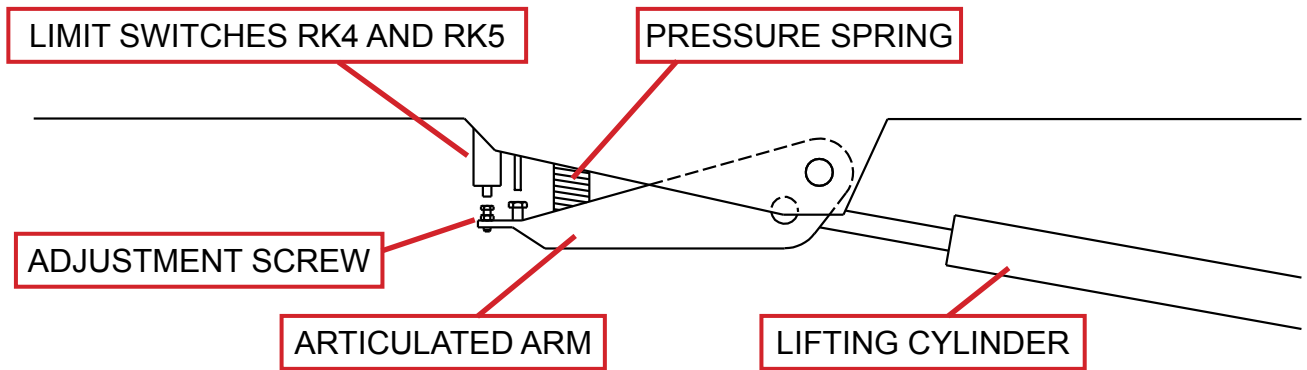

Check the correct adjustment of the outreach limit switches

For the test, keep the same carefully weighed and placed test load on the platform, as used in the previous test.

To check the adjustment of outreach limit switch RK 4:

1. Drive the boom to a horizontal position from the chassis control panel.
2. First lower and then lift the platform with the levelling control to a horizontal position.

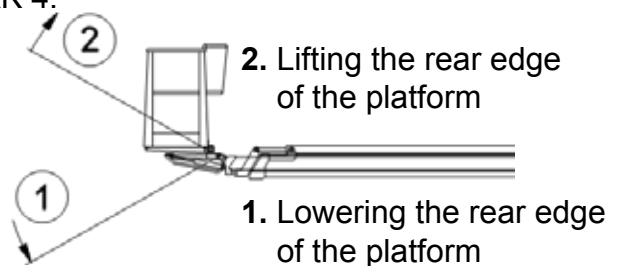

NOTICE

Before testing the outreach, the platform must be driven with the levelling control to a horizontal position so that that the last stage of the adjustment procedure is lifting of the rear edge. Otherwise you may not get the correct result.

3. Extend the telescope until it stops. Do not correct the position of the platform.
4. Make sure that a red signal light on the platform is burning.
5. Measure the stroke (L) and compare it to the values given below.
The length shall be: 160XT II: L = 1925 mm + 0 mm / - 50 mm
 180XT II: L = 2300 mm + 0 mm / - 50 mm
 210XT II: L = 3025 mm + 0 mm / - 50 mm

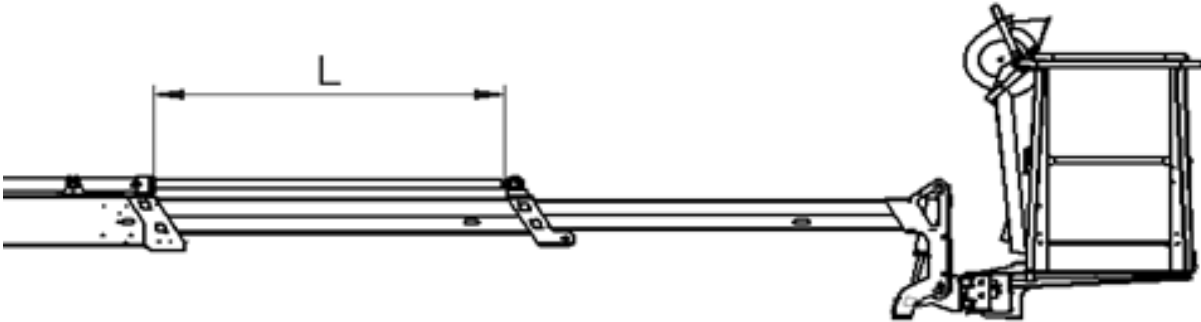

6. If the stroke is too long, adjust the limit switch and secure its position with a seal.

The overload limit-switch RK5 will back up if the outreach limit switch RK4 for some reason would not work. To check the adjustment of overload limit switch RK 5

1. Disable the RK4 for testing by disconnecting the conductor from the terminal X1:43 and connecting the terminals X3:25 and X1:41 inside the chassis control centre with a jumper lead for measuring.
2. connect the points X1 and X2 of the relay SR3 using another jumper lead.
3. Retract the telescope and then extend it again
4. Measure the stroke (L) and compare it to the values given below.

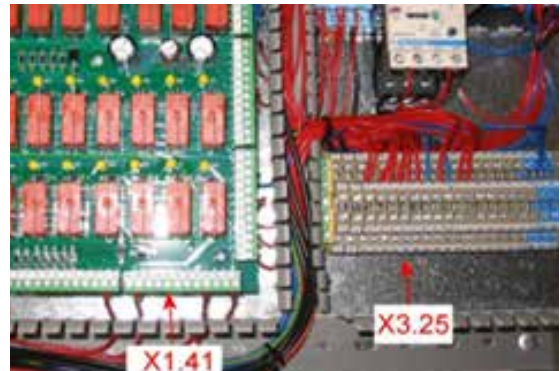

The length shall be: 160XT II: L = 2175 mm + 0 mm / - 50 mm
 180XT II: L = 2570 mm + 0 mm / - 50 mm
 210XT II: L = 3525 mm + 0 mm / - 50 mm

5. If the stroke is too long, adjust the limit switch and secure its position with a seal.
6. Remove the jumper leads and restore the operation of the RK4 by connecting the conductor to the terminal block X1:43 .
7. Put the cover back in its place

 WARNING	<p>The correct operation of both RK4 and RK5 limit switches must be ensured at every annual service. If the outreach or overload limits are adjusted, make sure that the RK4 is not disabled and that both limit switches work correctly after the adjustment.</p>
--	--

4.3.20. Inspection of the operating controls on the platform

Check the operating controls on the platform

- check the overall condition of the electric appliances inside the box and spray with moisture repellent, if necessary
- check the cables and the tightness of the cable clamps
- test the sound signal, emergency stop, emergency descent and retraction of the telescope
- test all movements. Check that all the movements stop when the control is released

4.3.21. Test loading



WARNING

The correct operation of outreach- and overload limit switches RK4 and RK5 must be done before test loading!

(I)

1. Place the lift on an even surface with good carrying capacity. Drive the outriggers to their lowest position (the minimum support width).
2. Raise the boom, turn it to the side from the transport support and lower it to the ground.
3. Put a weighed load of 215 kg on the platform (I).
4. Lift the boom to as high as it goes and extend the telescope to its full length (maximum lifting height).
5. Lower the boom until the safety device stops the movement.
6. Turn the boom round over 360°.
7. Retract the telescope and lower the boom to a horizontal position.
8. Extend the telescope until the safety limit switch RK4 stops the movement.
9. Compare the outreach with the reach diagram. If necessary, readjust according to the instructions "Adjustment of the outreach and overload limit switches" (see point "Regular servicing").
10. Establish the standing stability in this situation by turning the lift round over 360°.

(II) Carry out the same procedure with a platform load of 80 kg

Check the structures after test loading.

After the above mentioned test loadings (case I and case II) and the subsequent inspection have been completed without finding any defects in the structure or stability of the lift, the lift may be used inside the permitted operating range presented in the reach/platform load diagram of this manual.

The max. allowed platform load is 215 kg.

In conjunction with the first, i.e. start-up inspection, each lift is subjected to a test loading with an overload of 50% and after that the supporting structures are thoroughly inspected.

4.3.22. Inspection of the anti-corrosion treatment

If needed, repeat the anti-corrosion treatment using e.g. Tectyl 210R anti-corrosion agent.

4.4. ADJUSTMENT OF THE MOVEMENT SPEEDS

Measuring devices required for the adjustment:

- volt-ohm-milliammeter with possibility to measure direct current (A)
- screwdriver with narrow tip for adjusting the trimmer

1. **Disconnect the conductor 523 from the connector K25B.22 on the cover of the LCB centre. Connect the volt-ohm-milliammeter between the connector K25B.22 of the relay, and the conductor 523 as shown in pic01.**
2. **Connect the measuring leads to the direct current inlets of the volt-ohm-milliammeter, and turn the selector switch of the meter to the position (max. current $I_{max}=2A$).**
Lift the machine off the ground with the outriggers for operating the boom.
3. **Turn the key-switch to position 3; the power unit does not have to be running.**
4. **Check that the adjustable resistors TR9, TR10, TR11 and TR12 on the circuit card of the main centre have been turned counter-clockwise to their extreme positions.**



CONTROL CARD SCREWS

1. Maximum current I_{max}
2. Minimum current I_{min}
3. Frequency adjustment
4. Intensity of frequency
5. Ascending ramp
6. Descending ramp

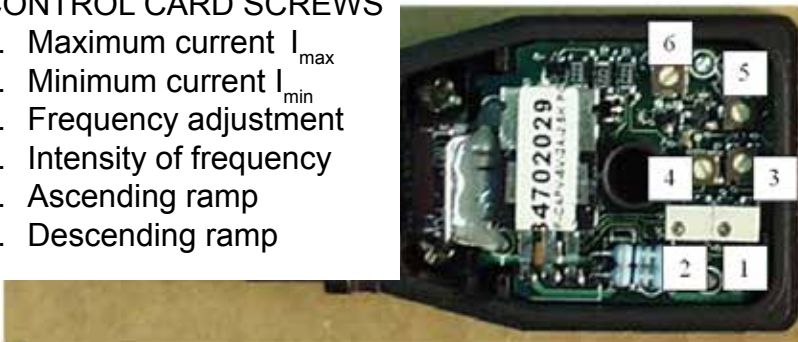

5. **Adjustment of the frequency (the lift in the boom-mode, the power unit is not running)**
Turn at first the adjustment screw 3 on the control card to its minimum position (extreme position counter-clockwise). After that, turn it 1/4 round clockwise.
6. **Intensity adjustment of frequency (the lift in boom-mode, the power unit is not running)**
Turn at first the adjustment screw 4 on the control card to its minimum position (extreme position counter-clockwise). After that, turn it 1/4 round clockwise.
7. **Adjustment of the ascending ramp (the lift in the boom-mode, the power unit is not running)**
Turn at first the adjustment screw 5 on the control card to its minimum position (extreme position counter-clockwise). After that, turn it 1/5 round clockwise.

8. Adjustment of the descending ramp (the lift in the boom-mode, the power unit is not running)

Turn at first the adjustment screw 6 on the control card to its minimum position (extreme position counter-clockwise). The descending ramp is not used.

9. Adjustment of min. current of the control card (the lift in the boom-mode, the power unit is not running)

9.1 The intensity of current increases as the screw is turned clockwise.

9.2 Adjust the minimum current to $I_{min}=300$ mA.

10. Adjustment of max. current of the control card (the lift in the boom-mode, the power unit is not running)

10.1 the max. current is adjusted via the screw 1 on the control card

10.2 drive the "boom up" movement

10.3 carry out the adjustment during the lifting, the current increases as the screw is turned clockwise

10.4 adjust the max. current to $I_{max}=1,500$ mA.

11.5 start the power unit, and extend the telescope for 10 seconds

Measure the stroke of the cylinder. The target is about 50 cm. If this cannot be achieved, you can try to increase the maximum current. The intensity of the current must not be too high, as then the adjustment range of the joystick will decrease.

11. The movement speeds are adjusted using the adjustable resistors on the circuit card in the main control centre. The speed of the following movements can be adjusted:

- TR9 = levelling the platform
- TR10 = the speed of the movements when controlled from the chassis control centre (affects the speed of all movements when controlled from the chassis centre)
- TR11 = lowering the boom
- TR12 = lowering the articulated arms

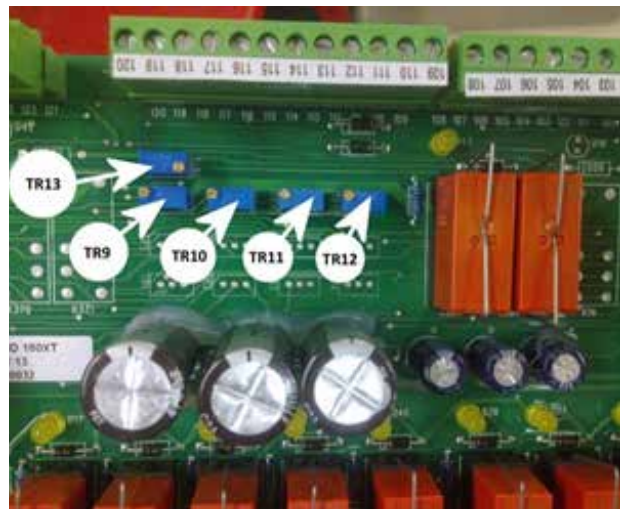

12. Adjustment of the movement speed from the chassis control centre (the lift in the boom-mode, the power unit is not running)

Drive the "boom up" movement and simultaneously adjust the intensity of current via the adjustable resistor TR10 to $I_{lower}=1500$ mA.

13. Adjusting the lowering speed of the boom

13.1 Drive the "boom down" movement and simultaneously adjust the intensity of current via the adjustable resistor TR11 to $I_{\text{lower}} = 1,250 \text{ mA}$.

13.2 Check the lowering speed of the boom -> start the power unit, and retract the telescope. Lift the boom until the floor of the platform reaches the height of 2,8 metres.

13.3 Lower the boom to its lowermost position (over a distance of 2 m). The lowering should take about 13 seconds. As necessary, adjust it via the trimmer TR11.

14. Lowering the articulated arms

Drive the "articulated arms down" movement and simultaneously adjust the intensity of current using the adjustable resistor TR12 to $I_{\text{lower}} = 1400 \text{ mA}$. Lift the articulated arms to their highest position, lower them all the way down and measure the elapsed time. The time shall be 20 seconds. As necessary, set the time as specified via the trimmer TR12.

15. Finally, disconnect the meter, and reconnect the lead S23

4.5. ADJUSTMENT OF OUTREACH- AND OVERLOAD LIMIT SWITCHES

While adjusting the limit switches, use the same test loads as in testing the limit switches.

The adjustment of the limit switches may only be carried out after the raising of the platform's rear edge

To adjust overload limit switch RK5

1. Remove the cover
2. Adjust the RK4 to make sure that the RK5 with certainty trips before it
3. extend the telescope and measure the stroke (L)
4. The length shall be: 160XT II: L = 2175 mm + 0 mm / - 50 mm
 180XT II: L = 2570 mm + 0 mm / - 50 mm
 210XT II: L = 3525 mm + 0 mm / - 50 mm
5. Tighten the locking nut for adjustment of RK5
6. Check once more the set values of the RK5. Check that the red signal light on the platform lights up.

To adjust overload limit switch RK4

7. Adjust the RK4 to closer than the RK5
8. Retract the telescope and then extend it again (in horizontal position)
9. Measure the stroke (L)
 The length should be: 160XT II: L= 1925 mm + 0 mm / - 50 mm
 180XT II: L= 2300 mm + 0 mm / - 50 mm
 210XT II: L= 3025 mm + 0 mm / - 50 mm
10. Tighten the locking nut for adjustment of RK4 and check the values once more
11. Apply a safety wire to the adjustment screws in such a way that it will be impossible to turn the screws outwards from the limit switches.
12. Apply a seal on the wire
13. Put the cover back in its place

4.6. SPECIAL INSPECTION

(INSPECTION AFTER AN EXCEPTIONAL SITUATION)

The inspection is required if the lift has been damaged in a manner which may affect its load-bearing capacity or safe operation.

- in this case the lift shall be inspected according to the instructions for the annual inspection
- the lift shall be subjected to a test loading and a stability test
- a protocol shall be drawn up for the inspection

5. FAULT FINDING

5.1. PROBLEMS WITH POWER SUPPLY

FAULT	REMEDY
-------	--------

1. Electric motor cannot be started by depressing the start button, although the selector switch 1 is in position LCB or UCB

The emergency stop button has jammed in the lower position.	Pull up the button and re-start the motor from the start button.
Fuse F1 has blown.	Replace the fuse (10A).
No mains supply (230 VAC) to the selector switch.	Check the extension cords, possible distribution boards and fuses.
Fault current safety switch has tripped.	Reset the fault current safety switch.
Voltage is supplied to the selector switch, but is not transmitted further.	Check the operation of the selector switch and replace it, if necessary.
Voltage is supplied to the selector switch, and is also transmitted further.	Check the operation of the motor's control contactor and thermo-relay as well as the operation of the relays that control the operation of the contactor.
Limit switch RK7 for the telescope chain has disconnected the contactor circuit.	Check the operation of the RK7 and readjust according to the instructions.
No direct-current supply (12VDC).	Main switch has been turned off, turn on the switch.

2. No power supply to the lift, although the main switch is on and the selector switch is in position LCB or UCB

Power supply has not been activated.	Press the start button to activate the power supply.
One of the fuses F1, F11 or F12 has blown.	Change the fuse and press the start button.
Battery is flat.	Recharge the battery.



Check, whether the fault is in the electric system or in the hydraulic system.

FAULT	REMEDY
-------	--------

3. Power unit does not start

Battery is flat.	Recharge the battery.
The mains cable is plugged.	Disconnect the plug from the mains.
No direct-current supply (12VDC).	Main switch has been turned off, turn on the switch.

4. Power unit cranks but does not start

Fuel tank is empty.	Fill the fuel tank.
Choke is off.	Press the choke button (cold engine).
Throttle lever in idling position.	Increase the engine revolutions.

5.2. PROBLEMS WITH MOVEMENTS

FAULT	REMEDY
-------	--------

5. None of the platform movements is operational, although the electric motor is running and the selector switch is in position 2 or 3

Green signal light for outriggers is not illuminated.	Check the operation of the outrigger limit switches RK11, RK12, RK13 and RK14.
Green signal light for the outrigger limit switches is illuminated, but the boom movements do not operate.	Check the operation of the safety relay SR2 for the outrigger circuit.
Boom has been overloaded.	Retract the telescope via buttons 6 or 21 until the platform returns inside its operating range (the green light in the platform control centre is illuminated).

6. Outriggers do not move

Boom is not resting on the transport support.	Drive the boom onto the transport support.
The selector switch is in the wrong position.	Turn the selector switch to position LCB.
Limit switch on the boom support has not closed.	Drive the boom onto the transport support and check the operation of the limit switch RK3.

7. Malfunctions of platform movements – only one of the movements can be operated

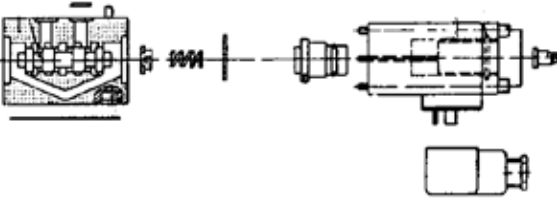
<p>Irregular and indefinite malfunctions.</p> 	<p>Make sure that the hydraulic oil and the filter have been changed.</p> <p>Thoroughly clean the solenoid valve spools and housings (requires utmost cleanliness – particles, that cause malfunctions, cannot possibly be spotted with the naked eye).</p> <p>Also temporary contact failures in the joysticks may cause malfunctions.</p> <p>Spray with moisture repellent.</p>
---	---

Lifting and lowering of the boom and the extension of the telescope are not operational, the red light is illuminated on the platform and in the chassis control centre, and the buzzer is audible.	The boom has been overloaded; retract the telescope and retry the operation (automatic reset).
---	--

FAULT	REMEDY
--------------	---------------

8. Some of the boom movements is not operational

	Refer to item 4. Electric valve is open. Remedy as instructed above in conjunction with the seizure of the electric valve spool.
The wrong movement works when operating for example the lifting of the boom.	Some of the solenoid valves for the boom movements is jammed in the open-position. Wash carefully the spool and the housing.

9. Telescope movement does not operate

	Refer to item 4. Check that the solenoid valve of the telescope is not stuck in the centre or in the lowering position.
--	--

10. None of the outriggers moves although the selector switch is in position LCB

The boom does not rest properly on the support.	Check the boom support and the operation of the RK3.
Electric valve for movement of boom/ outriggers does not operate (jams in the centre position).	For remedy, refer to item 4.

11. Boom movements are too fast or too slow

	Check the movement speed adjustments according to instructions.
--	---

5.3. DRIFTING OF BOOM OR OUTRIGGERS

FAULT	REMEDY
--------------	---------------

12. Boom drifts slowly downwards

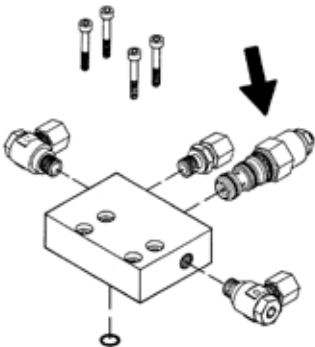
 <p>The load regulation valve leaks.</p>	<p>Remove and clean the valve.</p> <p>Check the condition of the o-rings.</p> <p>Install the valve carefully - the correct tightening torque is 60 Nm.</p> <p>If necessary, replace the valve.</p>
---	--

13. Telescope retracts slowly

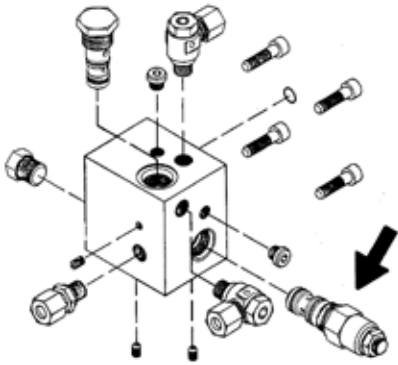
 <p>The load regulation valve leaks.</p>	<p>See item 12.</p>
--	---------------------



FAULT	REMEDY
-------	--------

14. Platform drifts backward

Double load regulation valve on the bottom side is leaking.	See item 12.
Load regulation valve under the platform is leaking.	See item 12.

15. Platform drifts forward

Double load regulation valve on the rod side is leaking.	See item 12.
--	--------------

16. Outrigger does not stay in the support position (see illustration)

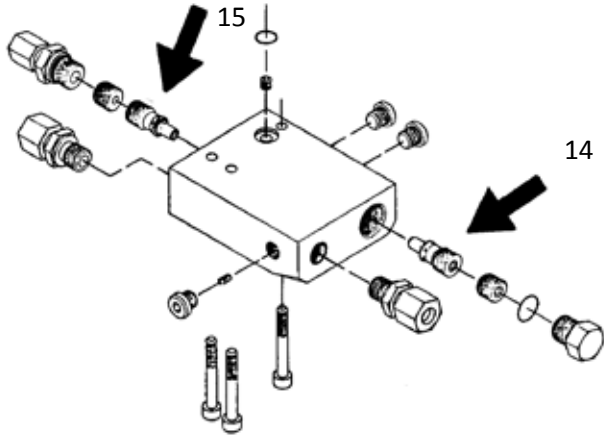
 <p>The load regulation valve on the bottom side is leaking.</p>	<p>See item 12 (load regulation valve). Tightening torque 55 Nm.</p>
--	--

17. Outrigger does not stay in the transport position

Load regulation valve on the rod side is leaking.	See item 12.
---	--------------

18. Driving device does not operate, although the selector switch is in position LCB

Boom is not resting on the transport support.	Drive the boom onto the support.
Electric valve for movement of boom/ outriggers does not operate (jams in the centre position).	For remedy, refer to item 7.

5.4. PROBLEMS WITH TOWING

FAULT	REMEDY
--------------	---------------

19. Too low braking force

Too much play in the brake system.	Adjust the brakes.
Brake linings not yet run-in.	Pull the parking brake lever slightly and drive 2-3 kilometres.
Brake-shoes "glazed", dirty or oil on the friction surfaces.	Replace the brake-shoe sets. Clean the friction surfaces of the brake drum.
Overrun brake jams.	Lubricate.
Brake rod jammed or bent.	Repair.
Brake wires rusty or cracked.	Replace the wires.

20. Braking uneven and jerky

Too much play in the brake system.	Adjust the brake system.
Shock absorber of the overrun device faulty.	Replace the shock absorber.
Reverse automatics – brake-shoe jams in the carrier.	Replace the brake-shoe in the carrier.

21. The brakes drag (only one of the wheels brakes)

Brake units wrongly adjusted.	Readjust the brake units according to the instructions. Also refer to point 19 for possible cause.
-------------------------------	---

22. Lift brakes as soon as the engine speed is decreased

Shock absorber of the overrun device faulty.	Replace the shock absorber.
--	-----------------------------

23. Reversing forced or impossible

Brakes have been adjusted too tight.	Adjust the brakes.
--------------------------------------	--------------------



FAULT	REMEDY
-------	--------

24. Wheel brakes overheat

Brake system wrongly adjusted.	Adjust the brake system.
Wheel brake dirty.	Clean the wheel brake.
Overrun brake – the transmission rod of the overrun jams.	Dismantle, clean and lubricate the transmission rod.
Parking brake not completely released.	Release the parking brake completely.

25. Ball-coupling is not locked

Inner parts of the ball-coupling dirty.	Clean and lubricate.
Tow-ball of the towing vehicle too large.	Measure the tow-ball. According to DIN74058, the diameter of the ball must be max. 50 mm and min. 49.5 mm. If the measure is different or the ball is not perfectly spherical, replace the ball.

Always, when changing brake-shoes, replace all the shoes on the axle.

Always, when assembling the brakes, make sure to install the springs, the brake-shoes and the expander in the right way.

When adjusting the brakes, turn the wheels forward (in the driving direction)!

Naturally, there are many possible reasons for malfunctions, but the following are the most common:

low supply voltage (long and thin supply cable)

the battery is flat (low voltage)

contaminants in the hydraulic system

loose electric connection or a contact failure caused by moisture

Keep the lift clean and protect it against moisture

6. HYDRAULIC SYSTEM

6.1. GENERAL INFORMATION OF HYDRAULICS

Activation of any of the movements requires that three electric valves be in operation simultaneously. The retraction of the telescope is an exception, as it requires simultaneous operation of two valves only. The valves are: the flow regulation valve (PR), the selection valve boom/chassis (1B) and the control valve for the movement in question. Using the selection valve boom/chassis is not required for retraction of the telescope.

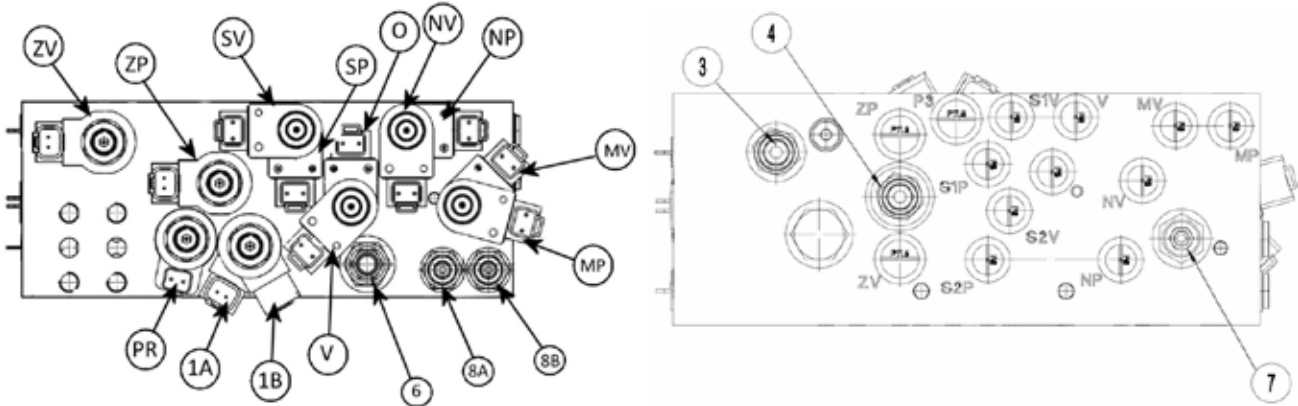

Valves:	3. Main pressure limit	4. Pressure limit for extension of the telescope
	6. Pressure limit for turning	7. Adjustment of the platform's levelling speed
	8A/B. Load regulation for levelling of the platform	
	1A/1B - selection "boom/chassis"	PR - Flow regulation valve (Propo)
	SV/SP - Articulated arms	NV/NP - Lifting of the boom
	MV/MP - Levelling of the platform	O/V - Turning of the boom
	ZV - Retraction of the telescope	ZP - Extension of the telescope

To control the valves manually in the case of malfunction, press the pins at the end of the electric valves. Take into account, when you operate valves manually, that you can only activate those movements that bring the work platform lower.

If the movements operate when controlled manually, the fault is in the electric system of the operating controls or the valve spools are dirty, which causes jamming (refer to the fault finding scheme, point 6).

If none of the movements operate, the fault is in the hydraulic system.

6.2. HYDRAULIC DIAGRAM

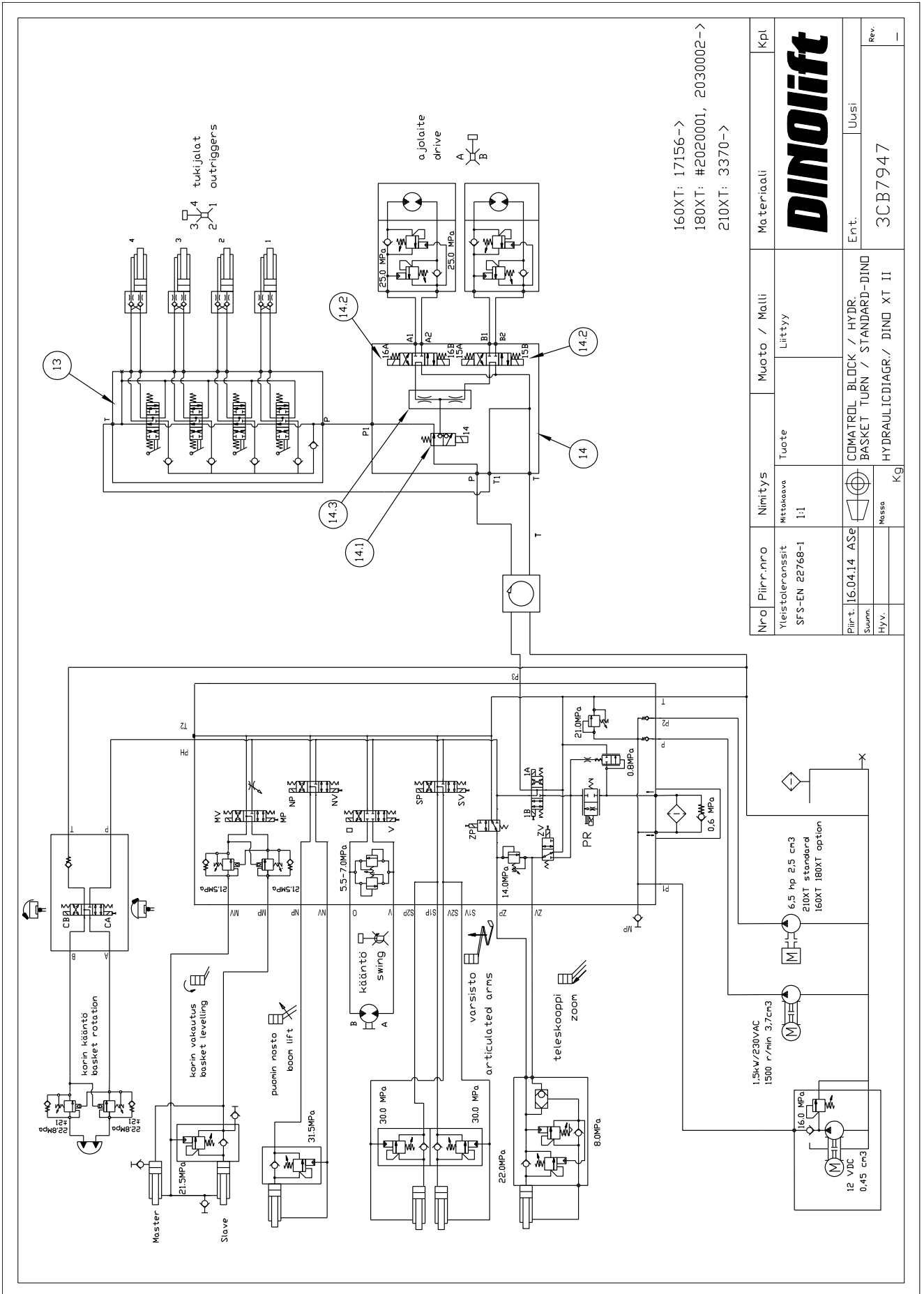

160XT: 17156-
 180XT: #202001, 2030002-
 210XT: 3370-

Nro	Piirr.nro	Nimitys	Muoto / Malli	Materiaali	Kpl
	Yleistalonissit SFS-EN 22768-1	Mittakaava 1:1	Litty		
Piirt.	16.04.14 ASE	COMATROL BLOCK / HYDR. BASKET TURN / STANDARD-DINO			
Summ.		HYDRAULICDIAGR./ DINO XT II			
Hyv.					
		Massa			3CB7947
					Ent. Uusi
					Rev. -

DINOLIFT

Automaattitasauksella / Automatic levelling / Automatische Nivellierung /
 Automatik nivellering / Automatisk avbalansering / Automatisk nivellering

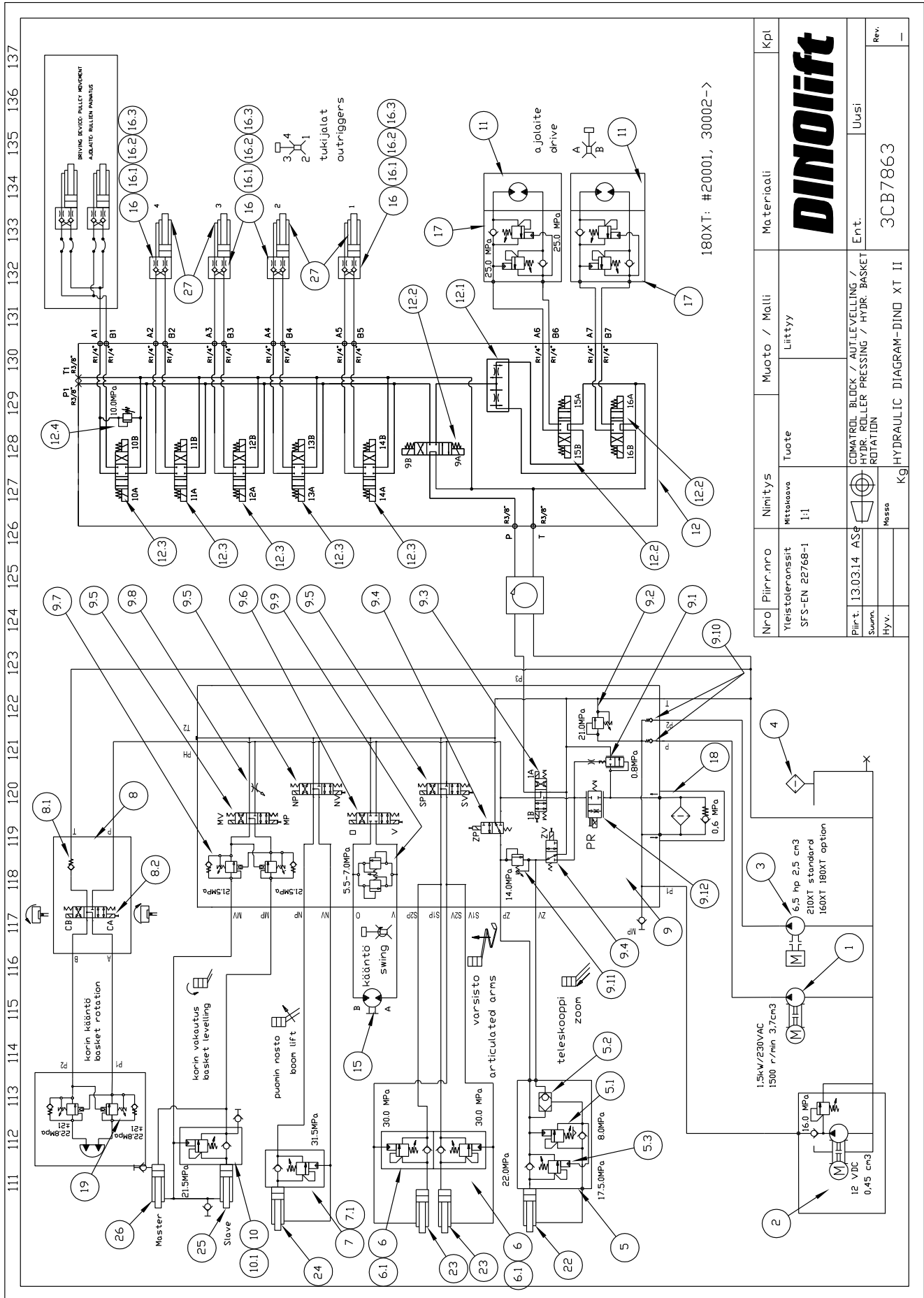

180XT: #20001, 30002->

Nro Piirr.nro	Nimitys	Muoto / Malli	Materiaali	Kpl
Yleistoleranssit SFS-EN 22768-1	Mittakaava 1:1	Liittyy	DINOLIFT	
Piirt. Suunn. Hyv.	13.03.14 ASG	GMATROL BLOCK / AUT.LEVELLING / HYDR.ROLLER PRESSING / HYDR. BASKET ROTATION	Ent. Uusi	Rev. -
	Massa	Kg	3CB7863	

7. ELECTRIC SYSTEM

7.1. ELECTRIC COMPONENTS

Device ID's used in the electric diagram and component functions are described in this chapter. Spare part numbers of main components are included in a separate spare part list.

CHASSIS CONTROL CENTRE (LCB), RELAYS

- K1:** START CONTACTOR (M1) FOR THE ENGINE
Control circuit fuse F2 10A.
- K2:** AUXILIARY RELAY FOR THE EMERGENCY STOP BUTTON
Switches off the mains supply (230VAC).
Control circuit fuse F2 10A.
- K3:** TURNING THE BOOM CLOCKWISE
Control circuit fuse F9 1,6A (Platform control centre) and F4 10A (Chassis control centre).
- K4:** TURNING THE BOOM COUNTER-CLOCKWISE
Control circuit fuse F9 1,6A (Platform control centre) and F4 10A (Chassis control centre).
- K5:** AUXILIARY RELAY FOR THE "BOOM DOWN" MOVEMENT
Control circuit fuse F9 1,6A (Platform control centre) and F4 10A (Chassis control centre).
- K6:** RETARDATION OF THE "BOOM DOWN" MOVEMENT
Decreases the maximum lowering speed of the boom by connecting a resistor to the control circuit of the control card.
Control circuit fuse F9 1,6A (Platform control centre) and F4 10A (Chassis control centre).
- K7:** AUXILIARY RELAY FOR THE "BOOM UP" MOVEMENT
Control circuit fuse F9 1,6A (Platform control centre) and F4 10A (Chassis control centre).
- K9:** AUXILIARY RELAY FOR THE "TELESCOPE IN" MOVEMENT
Control circuit fuse F9 1,6A (Platform control centre) and F4 10A (Chassis control centre).
- K10:** AUXILIARY RELAY FOR THE "TELESCOPE OUT" MOVEMENT
Control circuit fuse F9 1,6A (Platform control centre) and F4 10A (Chassis control centre).
- K11:** LOWERING THE ARTICULATED ARMS
Control circuit fuse F9 1,6A (Platform control centre) and F4 10A (Chassis control centre).
- K12:** RETARDATION OF THE "ARTICULATED ARMS DOWN" MOVEMENT
Decreases the maximum lowering speed of the articulated arms by connecting a resistor to the control circuit of the control card.
Control circuit fuse F9 1,6A (Platform control centre) and F4 10A (Chassis control centre).
- K13:** RAISING THE ARTICULATED ARMS
Control circuit fuse F9 1,6A (Platform control centre) and F4 10A (Chassis control centre).
- K15:** LEVELLING THE PLATFORM
Levelling the platform backward
Control circuit fuse F9 1,6A (Platform control centre) and F4 10A (Chassis control centre).

- K16:** LEVELLING THE PLATFORM
Levelling the platform forward
Control circuit fuse F9 1,6A (Platform control centre) and F4 10A (Chassis control centre).
- K17:** CENTRE POSITION ACTIVATION OF THE JOYSTICK
Switches off the voltage from micro-switches of the joystick, if the dead-man-switch DMK has not been pressed while the joystick is in the centre position.
- K18:** CONTROL RELAY FOR THE ADDITIONAL RESISTORS CONTROLLING THE MOVEMENT SPEED
The relay switches over the control voltage from the propo-card to the adjustable resistor for the boom/levelling of platform.
When the relay is active, the control voltage is routed via the resistor TR10 (movement speed of the boom from the chassis control centre)
As the relay is not active the control voltage is supplied through the TR9 resistor (levelling of platform)
Control circuit fuse F9 1,6A (Platform control centre) and F4 10A (Chassis control centre).
- K19:** CHANGE-OVER RELAY FOR THE CONTROL VOLTAGE OF THE PROPO-CARD.
As the relay is active the control voltage to the Propo-card is supplied via additional resistors. As the relay is not active the control voltage is supplied to the joystick by means of which the control voltage is adjusted to desired value with the help of adjustable resistors inside the joystick.
Control circuit fuse F9 1,6A (Platform control centre) and F4 10A (Chassis control centre).
- K20:** FUNCTION RELAY FOR THE OUTREACH LIMIT SWITCH RK4
Switches off the “telescope out” movement as the RK4 operates. Delay about 1,2 sec.
Control circuit fuse F2 10A.
- K21:** AUXILIARY RELAY FOR SWITCHING OFF THE “BOOM DOWN” MOVEMENT.
Safety limit switch RK4 controls the relay which switches off the spool control circuit of the relay K5.
Control circuit fuse F2 10A.
- K22:** AUXILIARY RELAY FOR SWITCHING OFF THE “TELESCOPE OUT” MOVEMENT
Closing tip of the safety limit switch RK4 controls the relay which switches off the spool control voltage of the relay K10, delay 2.5 sec.
Control circuit fuse F2 10A.
- K23:** CHANGE-OVER RELAY ON THE CHASSIS
Controls the solenoid valve for selecting on the chassis.
Fuse F2 10A.
- K24:** CENTRE POSITION ACTIVATION OF THE JOYSTICK
Depressing the dead-man-switch DMK switches off the control voltage from the spool of the relay K17, which would otherwise disconnect the control voltage of the micro-switches on the joystick.
- K25:** CONTROL RELAY FOR THE 1B-VALVE
Switches the voltage of 12VDC to the selector valve of the boom.
- K25B:** CONTROL RELAY FOR THE PR-VALVE
When driving the chassis, switches the voltage of 12VDC directly to the PR-valve. When driving the boom, the points direct the adjusted current from the control card to the PR-valve.
- K26:** RPM-RELAY
Controls the combustion engine revolutions. Increases the revolutions when the control movement is active.
Control circuit fuse F9 1,6A (Platform control centre) and F4 10A (Chassis control centre).

- K27:** AUXILIARY RELAY FOR CURRENT SUPPLY TO THE DRIVING DEVICE
The relay is controlled by the limit switch RK3.
Fuse F3 10A.
- K28:** CONTROL RELAY FOR THE SOLENOID OF THE EMERGENCY DESCENT UNIT
Switches on the voltage supply to the emergency descent unit solenoid SR1
Fuse F7 10A.
- K29:** PREVENTION OF DUAL CONTROL
The relay is controlled by the emergency descent buttons S11 and S13
Control circuit fuse F7 10A.
- K31:** SWITCH-OFF-RELAY FOR THE COMBUSTION ENGINE
Fuse F2 10A.
- K32:** SWITCH-OFF-RELAY FOR THE COMBUSTION ENGINE
Fuse F2 10A.
- K33:** AUXILIARY STARTING RELAY FOR THE DIESEL ENGINE
- K34:** RELAY FOR PREVENTING THE ELECTRIC MOTOR FROM RESTARTING
Prevents the electric motor from starting after the failure in AC power supply by switching off the control voltage from the control contactor of the motor.
- K35:** RELAY FOR PREVENTING THE ELECTRIC MOTOR FROM RESTARTING
Connects the voltage supply to the relay K34, if the voltage in the control circuit of the contactor is switched off.
- K390:** CHANGE-OVER RELAY FOR OPTIONAL FUNCTIONS
When the relay is active, the lifting-lowering movements of the articulated arms are switched over to the joystick movements in the X-direction. When the relay is not active, the joystick movements in the X-direction control turning of the boom to the left and right.
- K391:** CHANGE-OVER RELAY FOR OPTIONAL FUNCTIONS
When the relay is active the in-out movements of the telescope are switched over to the joystick movements in the Y-direction. As the relay is not active lifting-lowering movements of the boom are switched over to the joystick movements in the Y-direction
- K40:** CONTROL OF THE COMBUSTION ENGINE CHOKE
Switches on the combustion engine choke.
Fuse F2 10A.
- K41:** SENSOR RELAY FOR THE AC SUPPLY
When the lift is connected to an AC supply, the relay switches off the start circuit and switches on the stop circuit of the combustion engine. The relay spool is controlled by the AC-voltage.
- K42:** START RELAY FOR THE COMBUSTION ENGINE
Fuse F2 10A.

- K60:** SWITCH-OFF-RELAY FOR THE FUNCTIONS CONTROLLED FROM THE CHASSIS CONTROL CENTRE
Switches off the voltage supply to all the other boom movements during levelling of the platform.
- SR2:** Safety relay monitoring the operation of the outriggers
The safety relay resets as soon as all the outrigger safety limit switches (RK11, RK12, RK13 and RK14) have closed. After that it is possible to operate the boom.
- SR3:** SAFETY RELAY FOR MONITORING THE OVERLOADING OF THE BOOM
Safety limit-switch RK5 controls the operation of the safety relay.
Overloading of the boom:
SR3 is disconnected. The safety relay is automatically reset upon return to the normal outreach range. The delay adjusted with the capacitors affects the tripping moment of the SR3.
If the RK5 fails:
SR3 is disconnected. The safety relay is not automatically reset but the due operation of the electric equipment must be checked. The delay adjusted with the capacitors affects the tripping moment of the SR3.
- SR4:** SAFETY RELAY FOR THE EMERGENCY STOP CIRCUIT
SR4 switches off control voltage from the engine control contactors.
The safety relay operates provided that the emergency stop buttons on the upper and lower control centres are in their upper positions and the chain limit switch RK7 is not active. In addition the contactors K1 and K2 must be inactive.
The safety relay will trip if one of the emergency stop buttons either on the upper or on the lower control centre is depressed or the chain limit switch is activated.

CHASSIS CONTROL CENTRE (LCB), SWITCHES

- S1:** LOCKING EMERGENCY STOP SWITCH
Stops all other functions except the emergency descent and the sound signal, which remain operational.
- S2:** START SWITCH
Controls the contactor of the electric motor and start solenoid of the combustion engine if the combustion engine is used.
- S3:** STOP SWITCH
Disconnects the control voltage from the control contactor of the electric motor and the stop relay of the combustion engine.
- S13:** START SWITCH OF THE EMERGENCY DESCENT SYSTEM
Controls the solenoid for the emergency descent unit which starts the unit and supplies the control voltage to the control levers while the the emergency descent system is in operation.
- S16:** TURNING OF THE BOOM TO THE RIGHT - LEFT
Non-locking lever switch (chassis control centre).
- S17:** BOOM UP-DOWN
Non-locking lever switch (chassis control centre).
- S18:** TELESCOPE IN-OUT
Non-locking lever switch (chassis control centre).
- S19:** ARTICULATED ARMS DOWN-UP
Non-locking lever switch (chassis control centre).

- S20:** LEVELLING OF THE PLATFORM FORWARD-BACKWARD
Non-locking lever switch (chassis control centre).
- S32:** TELESCOPE IN
Non-locking button switch. After the SR3 has tripped, the telescope can be retracted by depressing the button.
- S40:** COMBUSTION ENGINE CHOKE
Non-locking button switch. Depressing the button keeps the choke of the combustion engine active.

CHASSIS CONTROL CENTRE (LCB), OTHER ITEMS

- F1:** 1.6A FUSE FOR ACTIVATION CIRCUIT OF THE TIMER CARD
- F2:** 10A CONTROL FUSE FOR START CIRCUIT AND MONITORING CIRCUIT OF THE OUTREACH
- F3:** 10A CONTROL FUSE FOR THE DRIVING DEVICE
- F4:** 5A FUSE FOR CONTROL LEVERS AND JOYSTICK IN THE CHASSIS AND PLATFORM CONTROL CENTRES
- F5:** 1.6A CONTROL FUSE FOR THE DRIVING DEVICE
- F6:** 10A CONTROL FUSE FOR THE SOLENOID VALVES
- F7:** 10 A CONTROL FUSE FOR THE EMERGENCY DESCENT CIRCUIT
- F8:** 10A CONTROL FUSE FOR THE COMBUSTION ENGINE
- F12:** TIMER CARD FUSE 16A
- H3:** YELLOW LED SIGNAL LIGHT
Indicates the operation of the outrigger limit switches RK11-RK14.
- H4:** RED LED SIGNAL LIGHT
Indicates the tripping of the SR3.
- HM1:** HOUR METER
Measures the running hours of the machine.
- Q1:** TURN SWITCH WITH KEY
Selector switch for choosing the operating location.
1 = chassis + chassis centre
2 = platform
- TC:** TIMER CARD
Control card for supply voltage.
Disconnects the supply voltage from the lift after a preset delay (normally 1 hour)
Start buttons S2 and S6 are used for re-activation of the control voltage.
- TR9:** ADJUSTABLE RESISTOR
Adjustable resistor for the levelling speed of the platform.
- TR10:** ADJUSTABLE RESISTOR
Adjustable resistor for lowering speed of the boom.

- TR11:** ADJUSTABLE RESISTOR
Adjustable resistor for the movement speed when operating from the chassis centre.
- TR12:** ADJUSTABLE RESISTOR
Adjustment of the articulated arms' lowering speed.
- U1:** VOLTAGE METER
As the control voltage is connected the voltage meter indicates the alternating voltage reading.

PLATFORM CONTROL CENTRE (UCB), RELAYS

- K41b:** SENSOR RELAY FOR THE AC SUPPLY
Vaihtojännitteen ollessa kytkettynä on start/stop automatiikka toiminnassa.
- K50:** CONTROL RELAY FOR SIGNAL LIGHTS INDICATING THE STATE OF LOADING OF THE PLATFORM
The relay is controlled by the opening point of the limit switch RK4.
- K54:** SÄHKÖMOOTTORIN KÄYNNISTYKSEN AIKARELE
Start/stop automatiikka käyntiviive 3s.
- K61:** TURNING OF THE PLATFORM
Käännön aloitus aikarele.
- T13:** ADJUSTABLE RESISTOR
Korinkäännön nopeus.

PLATFORM CONTROL CENTRE (UCB), SWITCHES

- DMK:** DEAD-MAN-SWITCH
- JST:** JOYSTICK
As the right side of the rocker switch is depressed, the movements are: boom up - down and turn right - left)
As the left side of the rocker switch is depressed, the movements are: telescope in-out and articulated arms up-down.
- S4:** LOCKING EMERGENCY STOP SWITCH
Stops all other functions except the emergency descent and the sound signal, which remain operational.
- S5:** STOP SWITCH
Disconnects the control voltage from the control contactor of the electric motor and the stop relay of the combustion engine.
- S6:** START SWITCH
Controls the contactor of the electric motor and start solenoid of the combustion engine if the combustion engine is used.
- S10:** SOUND SIGNAL SWITCH
- S11:** EMERGENCY DESCENT SWITCH

Controls the solenoid for the emergency descent unit which starts the unit and supplies the control voltage to the control levers while the the emergency descent system is in operation.

- S12:** LEVELLING OF THE PLATFORM FORWARD-BACKWARD
Control switch, non-locking lever switch.
The levelling is operated by pressing the button S29 and turning the lever switch S12.
- S29:** SELECTOR SWITCH FOR LEVELLING OF THE PLATFORM
Non-locking button switch.
Switches on the control voltage to button switch S12 as the switch is depressed.
- S31:** TELESCOPE IN
Non-locking pushbutton for retraction of the telescope.
- S36:** TURNING THE PLATFORM TO THE LEFT-RIGHT
Non-locking lever switch.
The turning is operated by pressing the button S29 and turning the lever switch S36.
- S41:** COMBUSTION ENGINE CHOKE
Non-locking button switch. Depressing the button keeps the choke of the combustion engine active.

PLATFORM CONTROL CENTRE (UCB), OTHER ITEMS

- H1:** GREEN LED SIGNAL LIGHT
The platform inside the operating range.
- H2:** RED LED SIGNAL LIGHT
The platform at the border of the operating range.
- F9:** JOYSTICK FUSE 1.6A
- PR:** SOCKET OUTLET ON THE PLATFORM 230VAC 16A.
- ÄM2:** BUZZER
Indicates the operation of the safety limit switch RK5 and the emergency stop switches S1 and S4.

CONTROL CENTRE FOR THE DRIVING DEVICE (DCB)

- S24:** DRIVING STRAIGHT FORWARD AND BACKWARD
Non-locking lever switch.
- S25:** TURNING TO THE LEFT
Non-locking pushbutton.
- S26:** TURNING TO THE RIGHT
Non-locking pushbutton.

LIMIT SWITCHES

RK3: LIMIT SWITCH ON THE BOOM SUPPORT

Prevents the operation of the outriggers and the driving device if the boom is not resting on the support in the transport position. Controls the relay K30.

RK4: SAFETY LIMIT SWITCH FOR THE ADJUSTED OPERATING RANGE

The operation of the limit switch stops the “boom down” movement and the “telescope out” movement.

RK5: BACKUP LIMIT SWITCH FOR THE SAFETY LIMIT SWITCH RK4.

Trips after the preset delay (2,4 seconds) the safety relay SR3 which controls the sound signal AM2 and switches off the control voltage to the limit switch RK4.

RK7: SAFETY LIMIT SWITCH FOR THE TELESCOPE CHAIN.

Operation of the safety limit switch stops the electric motor. The limit switch switches off the control voltage to the contactor K1 after which only the emergency descent unit will operate.

RK8: SAFETY LIMIT SWITCH “TELESCOPE FULLY RETRACTED”

The limit switch closes when the telescope is completely retracted.

If the RK4 or RK5 has failed, the boom cannot be lowered until the telescope has been completely retracted and the points of the limit switch RK8 have closed.

RK11
- RK14: LIMIT SWITCHES ON THE OUTRIGGERS

The limit switch closes as soon as sufficient force is exerted on the outrigger.

Prevents the operation of the boom unless the outriggers are not firmly supported on the ground and all limit switches are not closed.

OTHER MARKINGS

B1: BATTERY 12VDC 44AH

E1: THERMORELAY FOR THE ELECTRIC MOTOR

F11: MAIN BATTERY FUSE 125A

J1: PLUG

M1: ELECTRIC MOTOR 230VAC 1.5kW

M2: EMERGENCY DESCENT MOTOR 12VDC
Max. operating time 10 min.

PL: ROTARY ADAPTOR
The electric circuits between the chassis and the turning device go through the electric rotary adaptor.

SR1: SOLENOID FOR THE EMERGENCY DESCENT UNIT
When energized, starts the emergency descent unit M2.

SPV: MAIN SWITCH
Disconnects the plus terminal of the battery.

T2: BATTERY RECHARGER
Charging voltage 13,8VDC 10A
Charges the battery if the mains supply is connected.

VVK: FAULT CURRENT SWITCH 25A 30 ms.

ÄM1: SOUND SIGNAL

7.2. ELECTRIC DIAGRAM

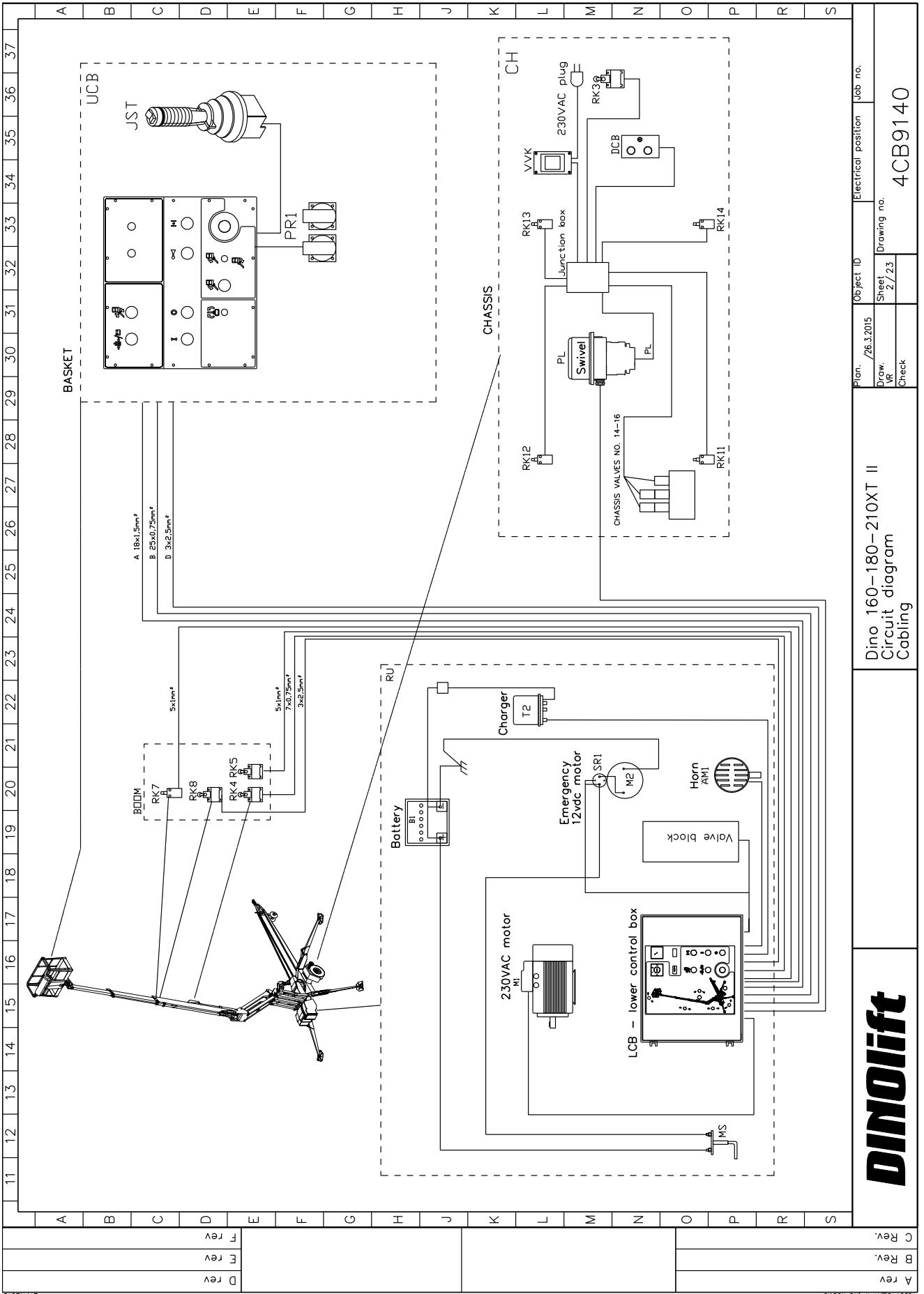

Rev. A	Object ID	Electrical position	Job no.
Rev. B	Plan: /26.3.2015	Sheet	4CB9140
Rev. C	Draw: VR	2/23	
	Check		

DINOLIFT

Dino 160-180-210XT II
Circuit diagram
Cabling

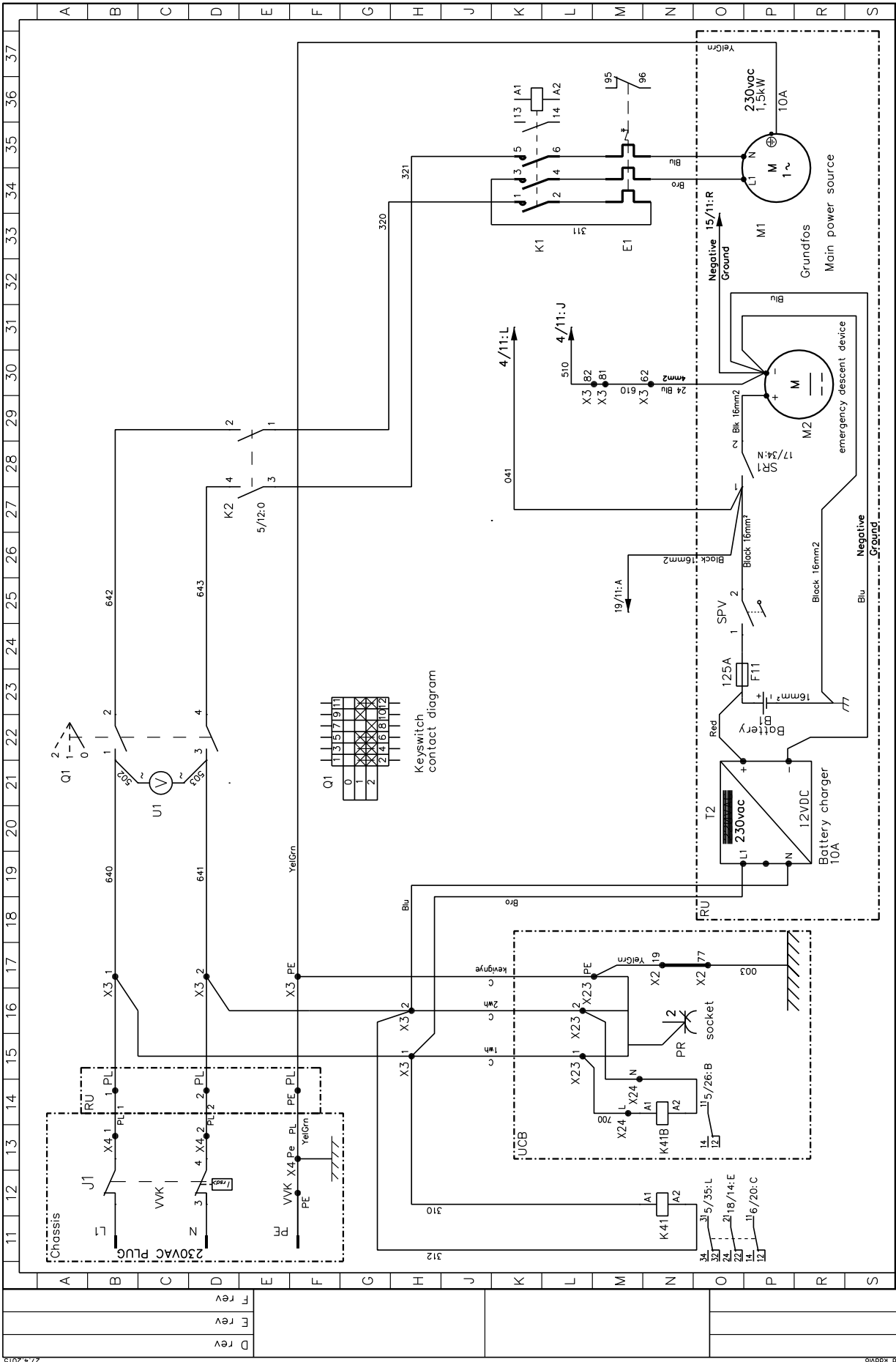

A Rev		Dino 160-180-210XT II		Object ID		Electrical position		Job no.	
B Rev		Circuit diagram		Plan		LCB		4CB9140	
C Rev		230Vac circuits		/26.3.2015		Sheet		Drawing no.	
				VF		3/23			
				Check					



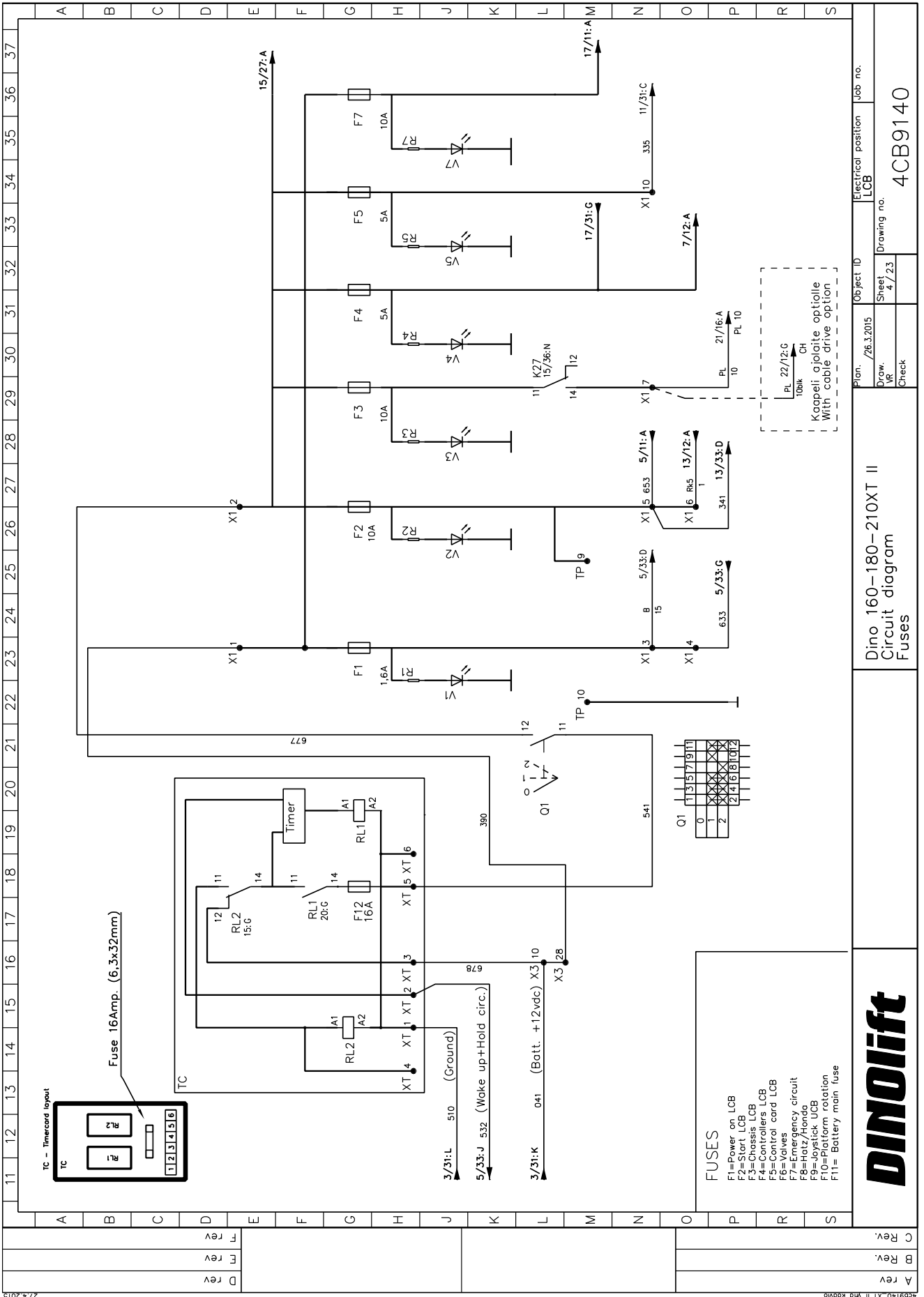

DINOLIFT

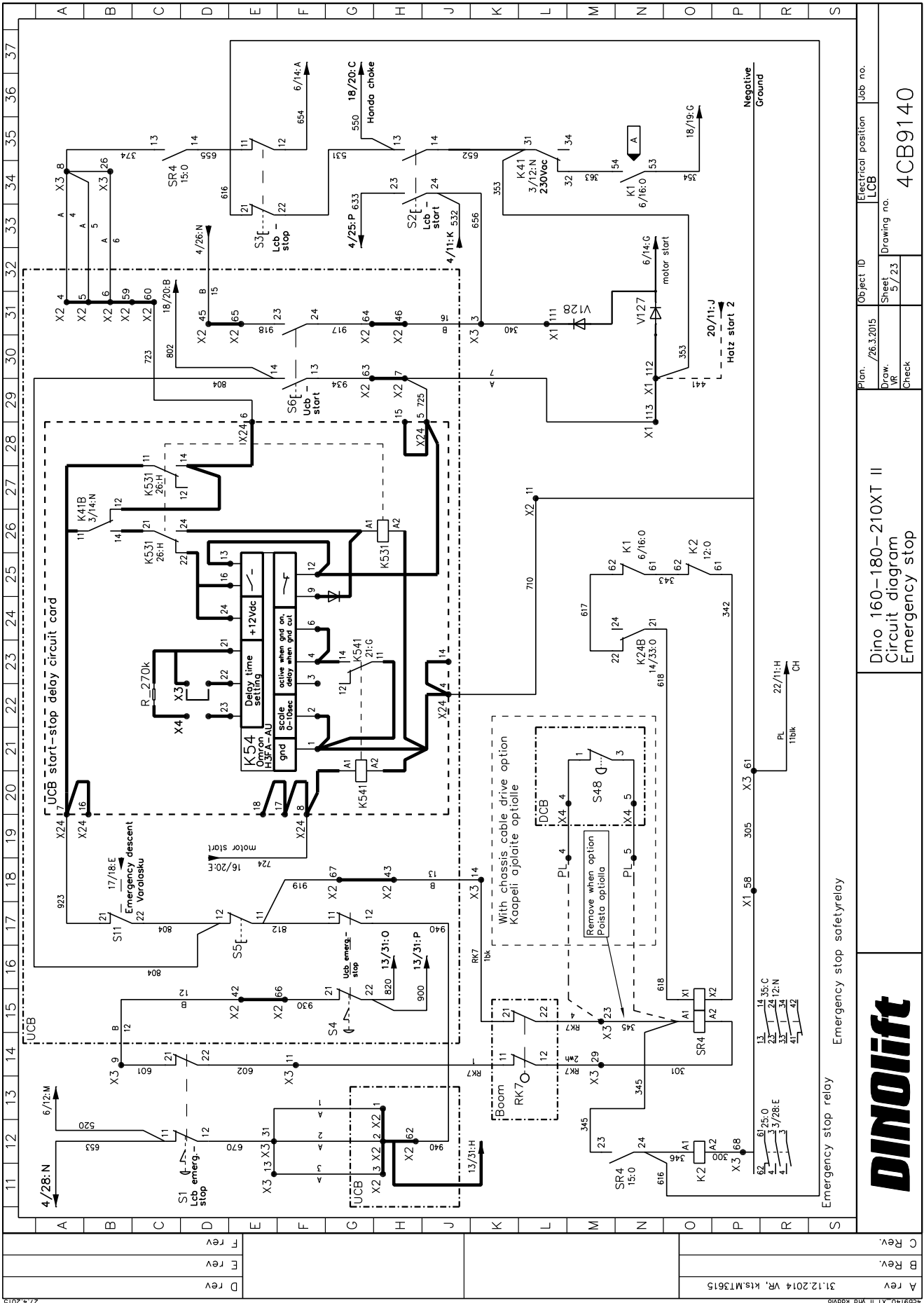

Emergency stop safetyrelay



Dino 160-180-210XT II
Circuit diagram
Emergency stop

Plan	/26.3.2015	Object ID	LCB	Electrical position	Job no.
Draw.	VP	Sheet	5/23	Drawing no.	
Check					4CB9140

A Rev	31.12.2014 VR, KIS, MTS615
B Rev	
C Rev	

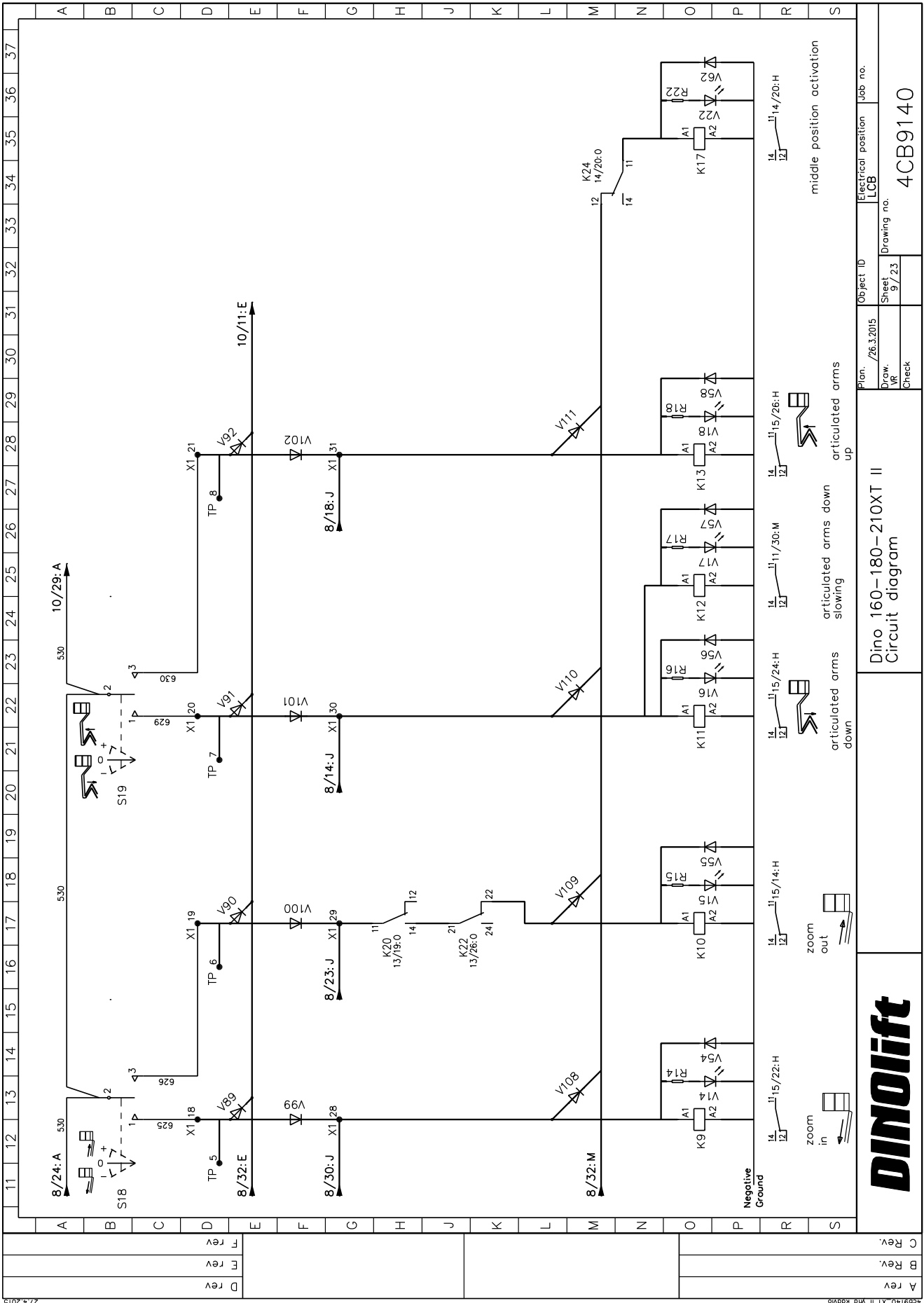

DINOLIFT

Dino 160-180-210XT II
Circuit diagram

Plan: /26.3.2015
Draw: Vp
Check:
Object ID: LGB
Drawing no: 4CB9140
Job no: 4CB9140

A rev	
B rev	
C rev	
D rev	
E rev	
F rev	

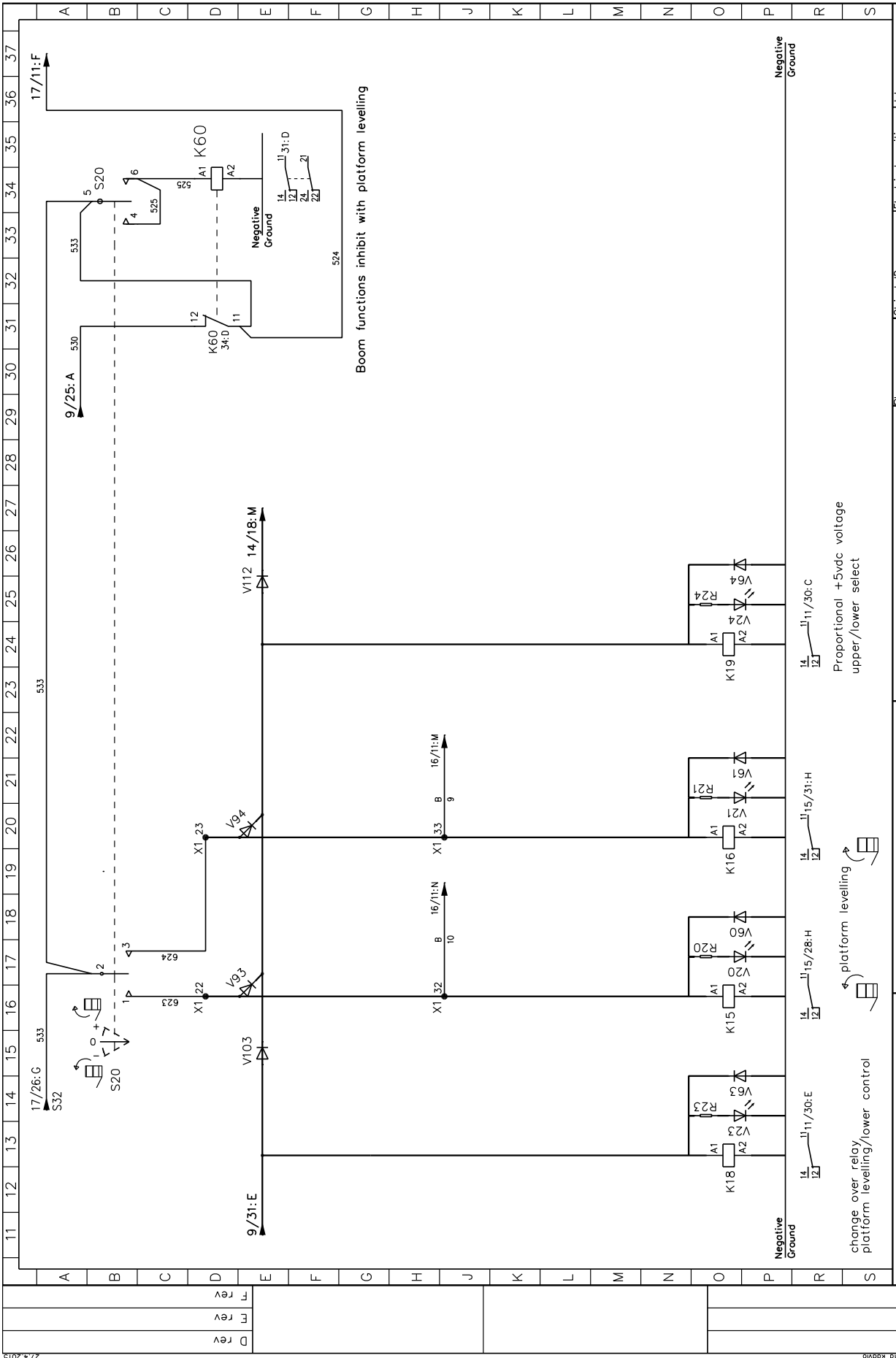

A rev		Dino 160-180-210XT II		Object ID		Electrical position		Job no.	
B rev		Circuit diagram		/26.3.2015		LCB		4CB9140	
C rev				Plan		Sheet		Drawing no.	
				10/23		10/23			
				Draw: VR		Check			



27.4.2015

4CB9140_XT II_MHD_K9076

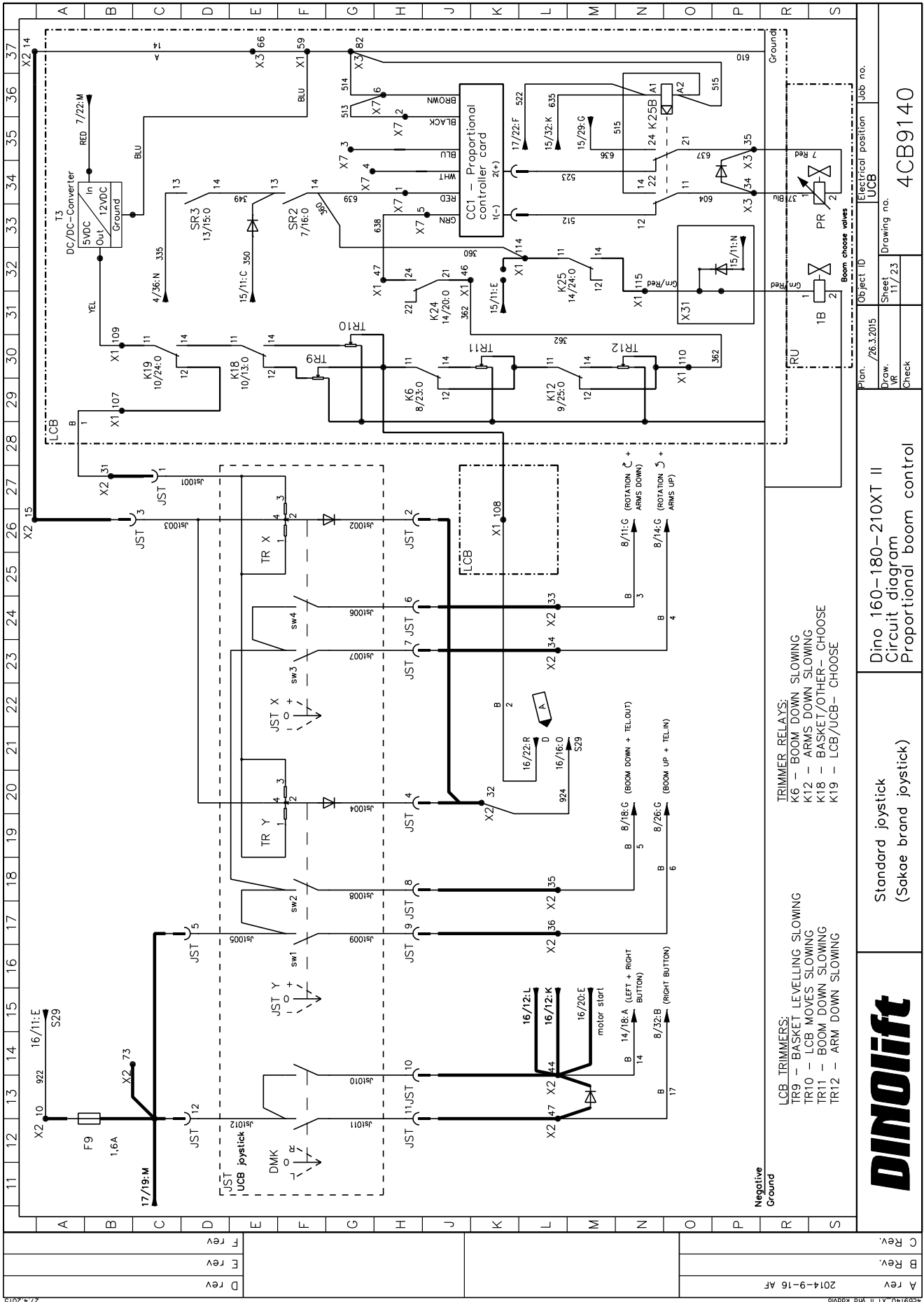

DINOLIFT

Standard joystick
(Sakae brand joystick)

Dino 160-180-210XT II
Circuit diagram
Proportional boom control

Object ID: 4CB9140
Drawing no. 11.7.23
Sheet 1

Electrical position: UCB
job no.

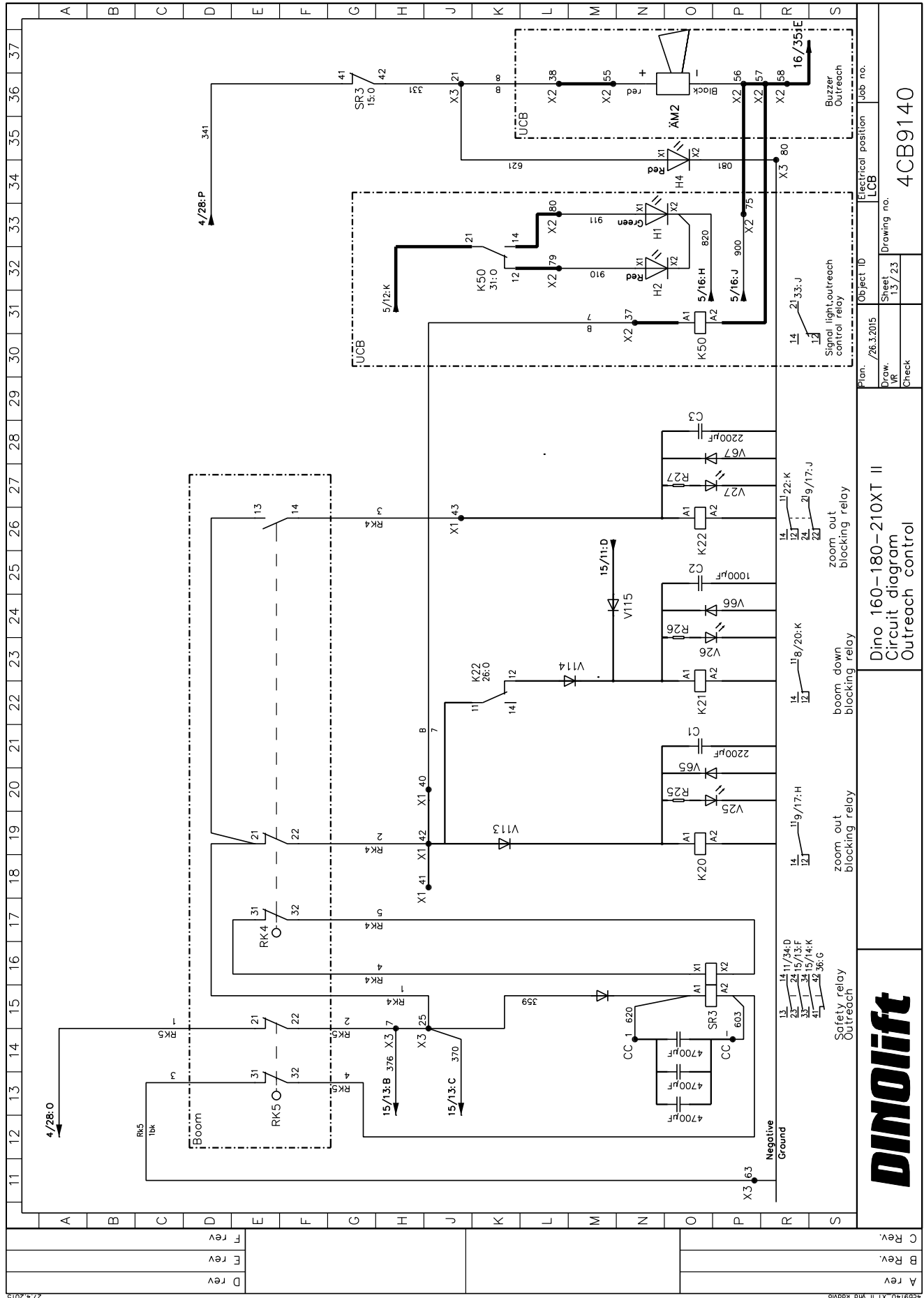

DINOLIFT

Dino 160-180-210XT II
Circuit diagram
Outreach control

Object ID: 26.3.2015
Electrical position: LCB
Job no.: 4CB9140

Plan: 26.3.2015
Sheet: 13/23
Drawn: VJ
Check:

A Rev	
B Rev	
C Rev	
D Rev	
E Rev	
F Rev	

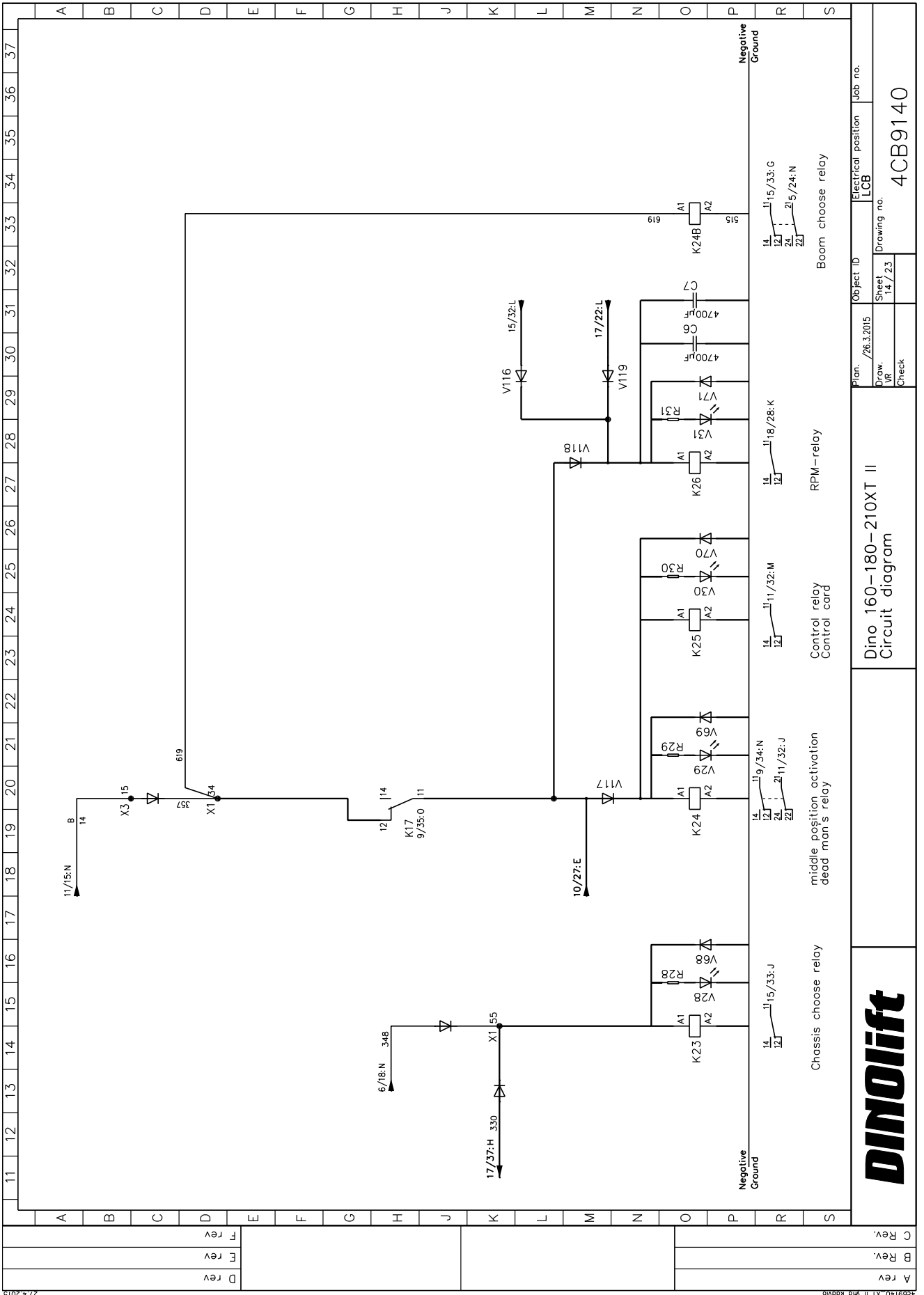

C Rev.	Object ID	Electrical position	Job no.
B Rev.	/26.3.2015	LCB	
A Rev.	Draw: VR	Sheet 14/23	Drawing no. 4CB9140
	Check		

DINOLIFT

Dino 160-180-210XT II
Circuit diagram

Boom choose relay

RPM-relay

Control relay

middle position activation
dead man's relay

Chassis choose relay

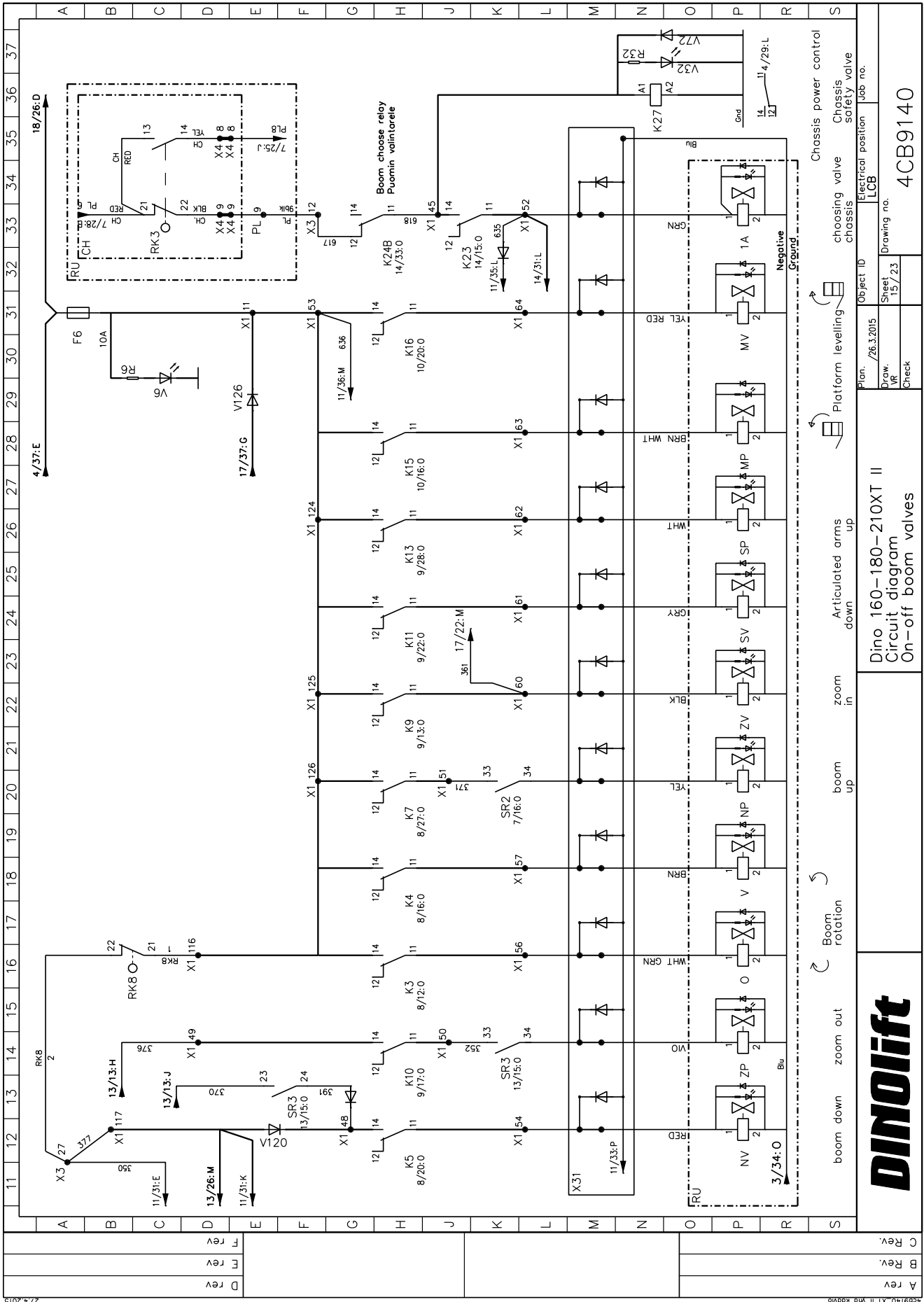

DINOLIFT

Dino 160-180-210XT II
Circuit diagram
On-off boom valves

Object ID
choosing valve
chassis
LCB
Electrical position
job no.
4CB9140

Plan: /26.3.2015
Draw: VJF
Check:
Sheet: 15/23
Drawing no.:

Chassis power control
Chassis safety valve

Platform levelling

Articulated arms
down
up

boom
up
down

zoom
in
out

boom
rotation

boom
down
up

boom
down
up

boom
down
up

boom
down
up

boom
down
up

boom
down
up

boom
down
up

boom
down
up

boom
down
up

boom
down
up

boom
down
up

boom
down
up

boom
down
up

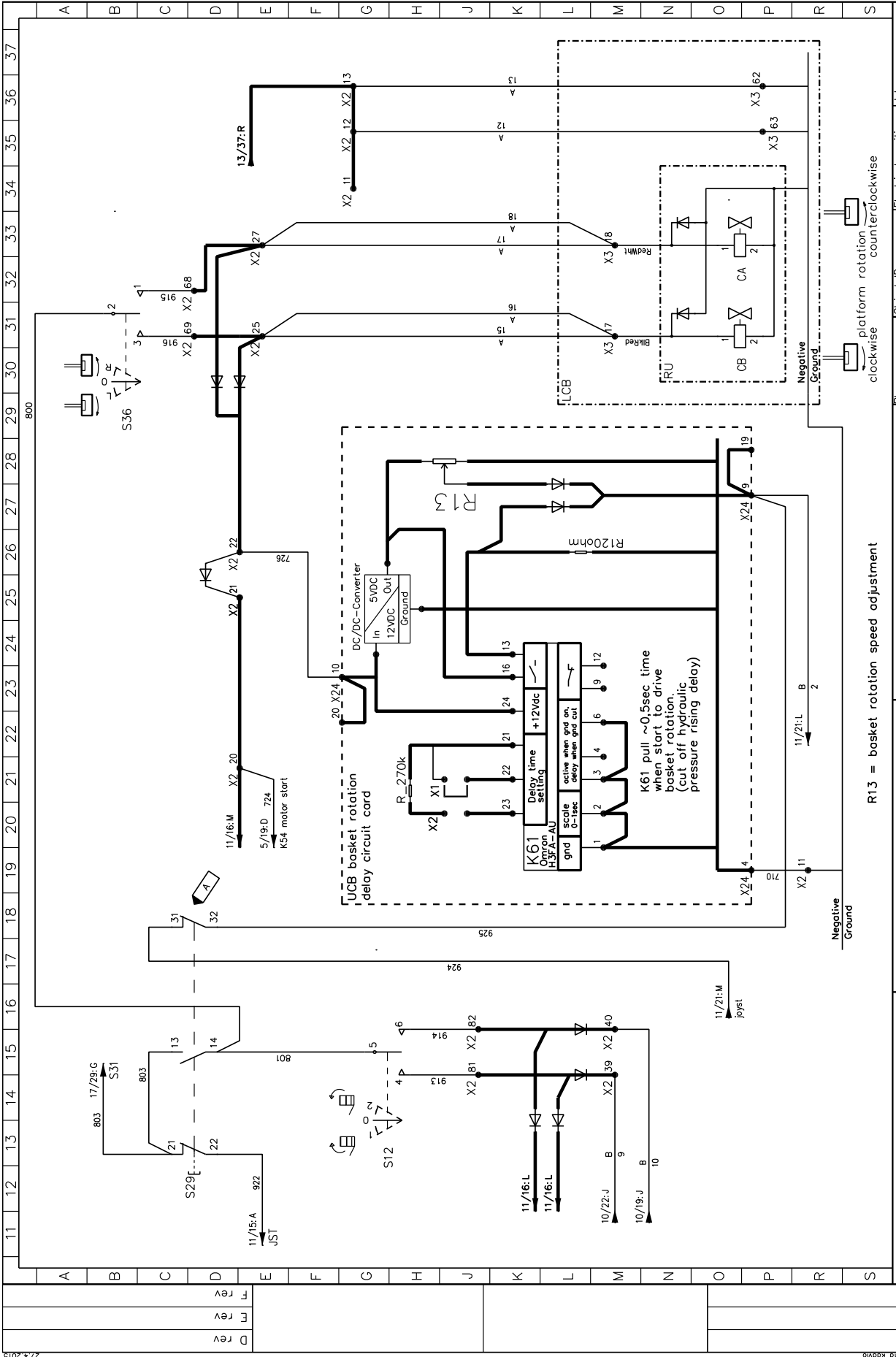

R13 = basket rotation speed adjustment

platform rotation counter-clockwise clockwise

DINOLIFT

Dino 160-180-210XT II
Circuit diagram
Basket level & turn

Plan: /26.3.2015
Draw: VR
Object ID: UCB
Sheet: 16/23
Drawing no: 4CB9140
Job no:

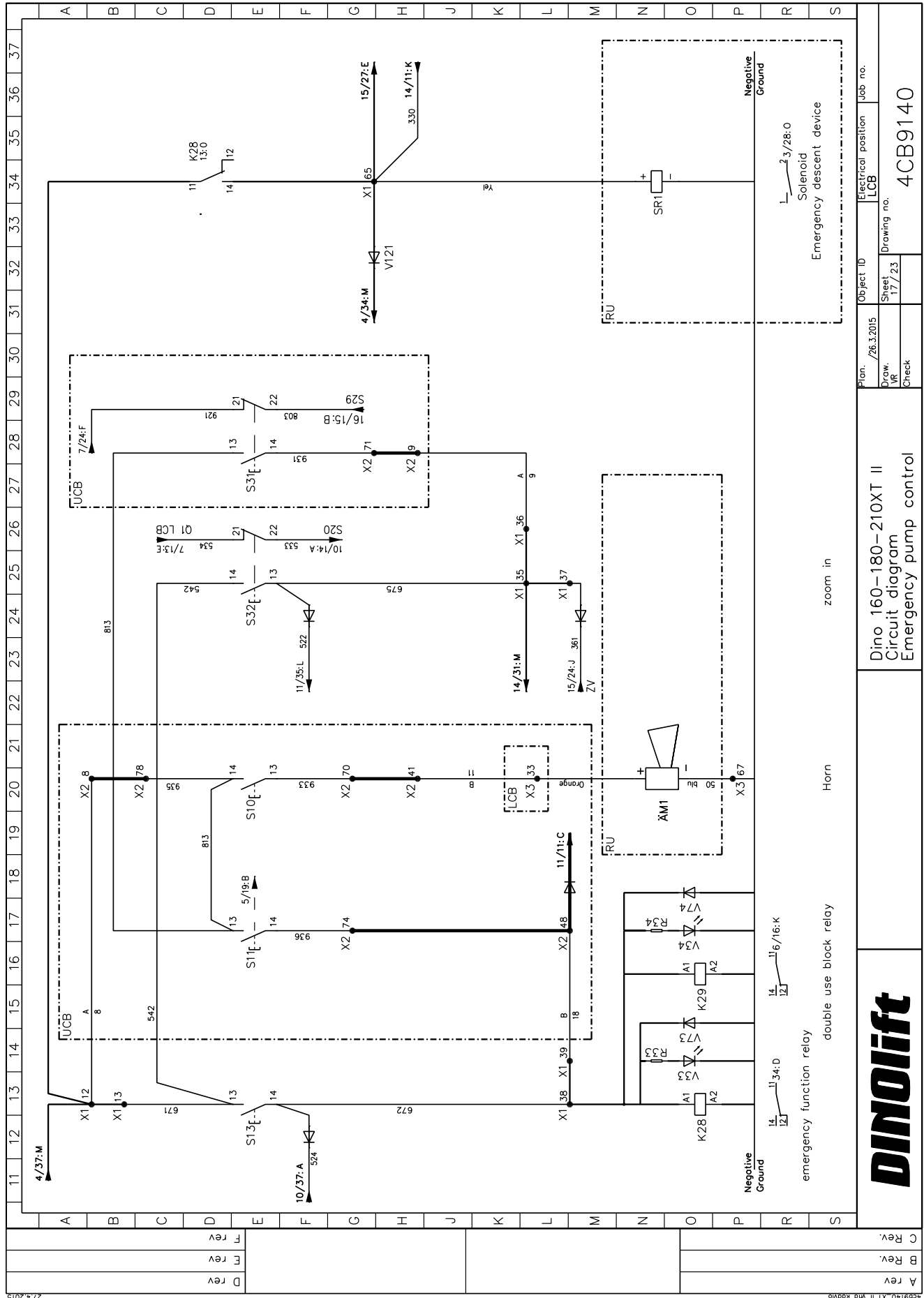

Object ID: LCB
 Drawing no.: 4CB9140

Plan: /26.3.2015
 Draw. Vp:
 Check:

Dino 160-180-210XT II
 Circuit diagram
 Emergency pump control

Horn
 zoom in

emergency function relay
 double use block relay

Negative Ground
 Solenoid
 Emergency descent device



C Rev.	Electrical position	Job no.
B Rev.	LCB	
A Rev.		

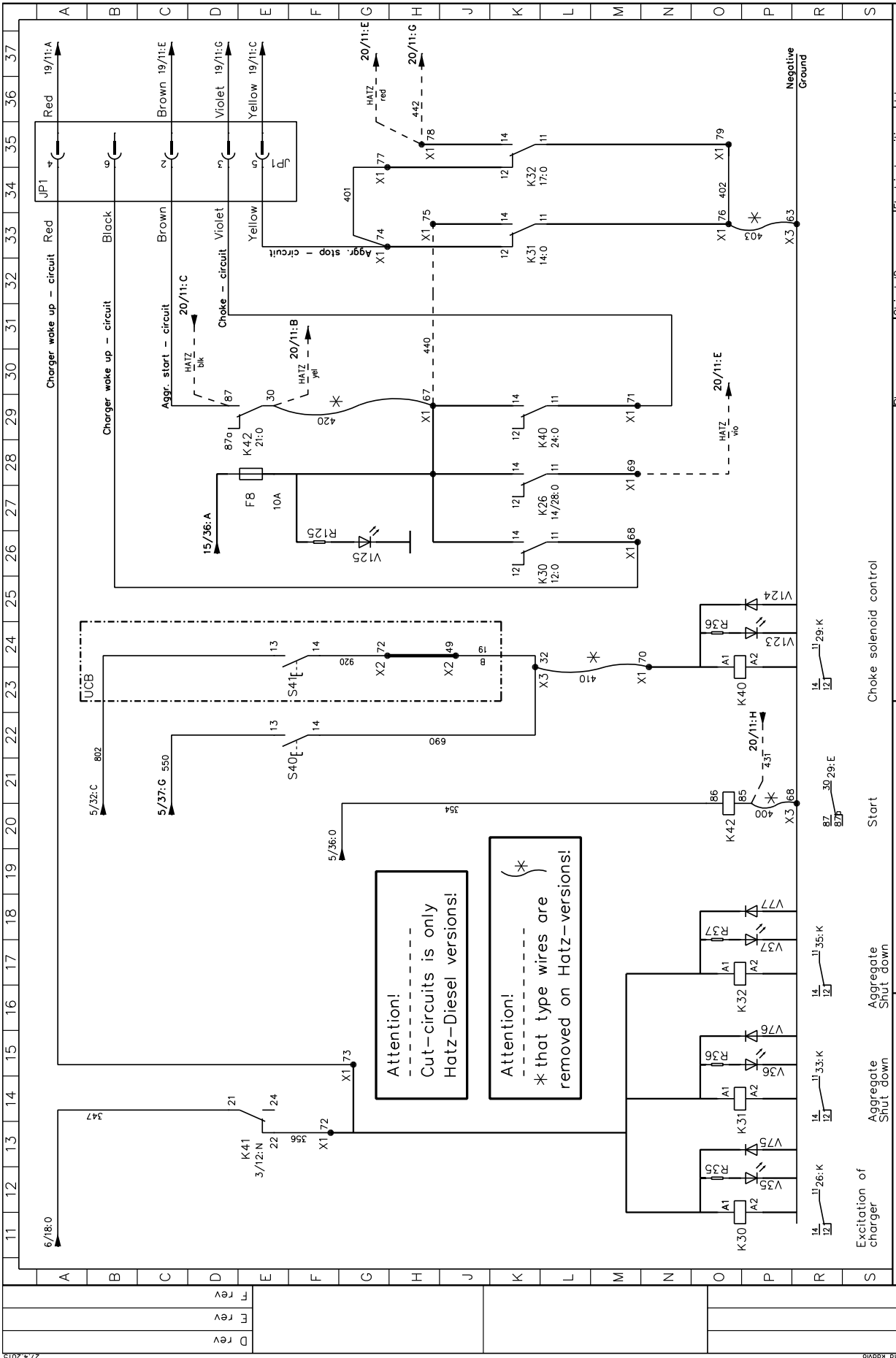

C Rev.		Object ID	Electrical position	Job no.
B Rev.		Plan. /26.3.2015	LCB	
A Rev.		Draw. VR	Sheet 18/23	Drawing no. 4CB9140
		Check		



Dino 160-180-210XT II
Circuit diagram
HONDA / HATZ option

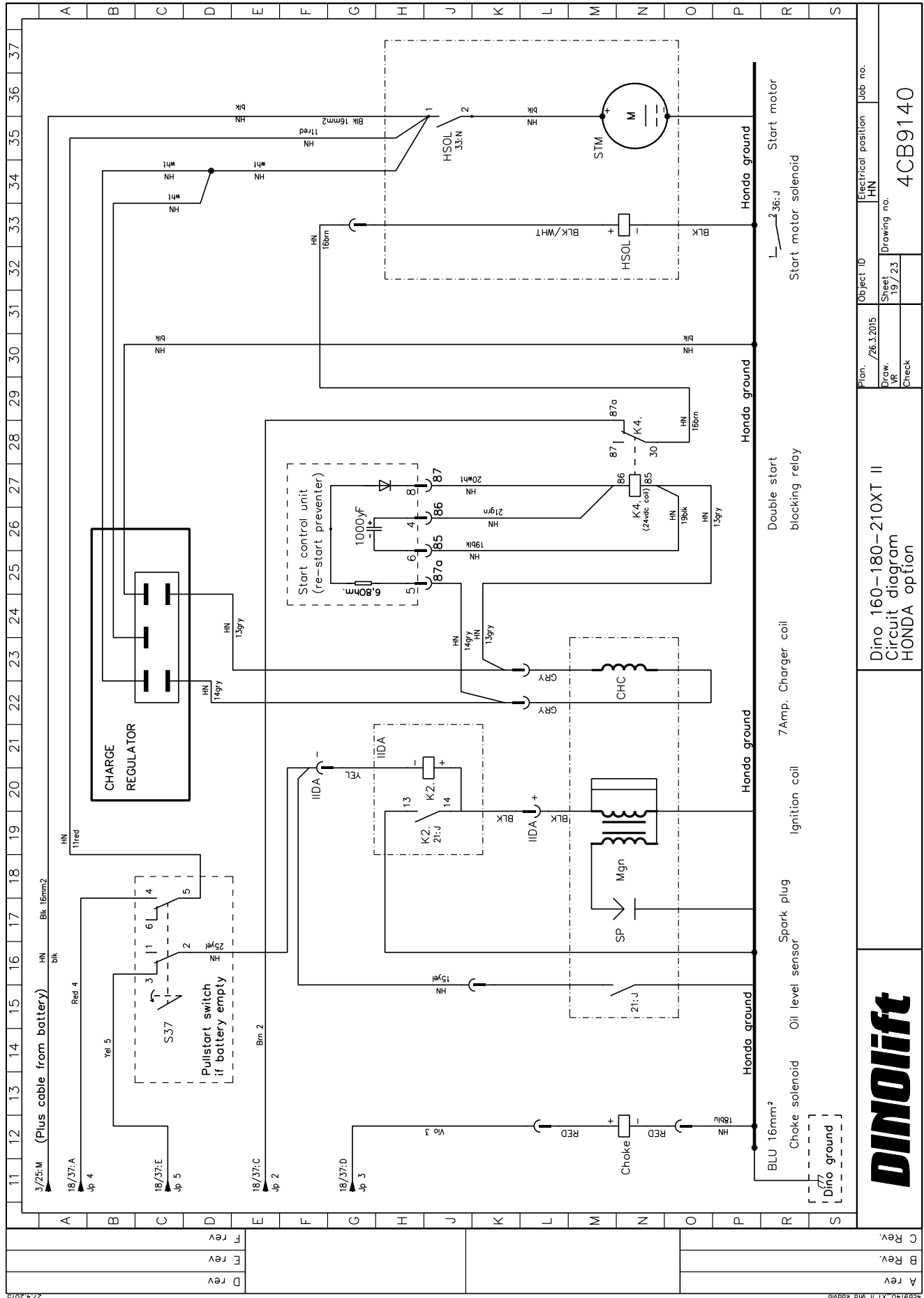

Object ID: HN
 Electrical position: HN
 Job no.: 4CB9140

Plan: /26.3.2015
 Draw: VJ
 Sheet: 19/23
 Check:

Dino 160-180-210XT II
 Circuit diagram
 HONDA option

7Amp. Charger coil
 Ignition coil
 Spark plug
 Oil level sensor
 Choke solenoid
 Start motor solenoid
 Start motor

DINOLIFT

C Rev.
 B Rev.
 A Rev.

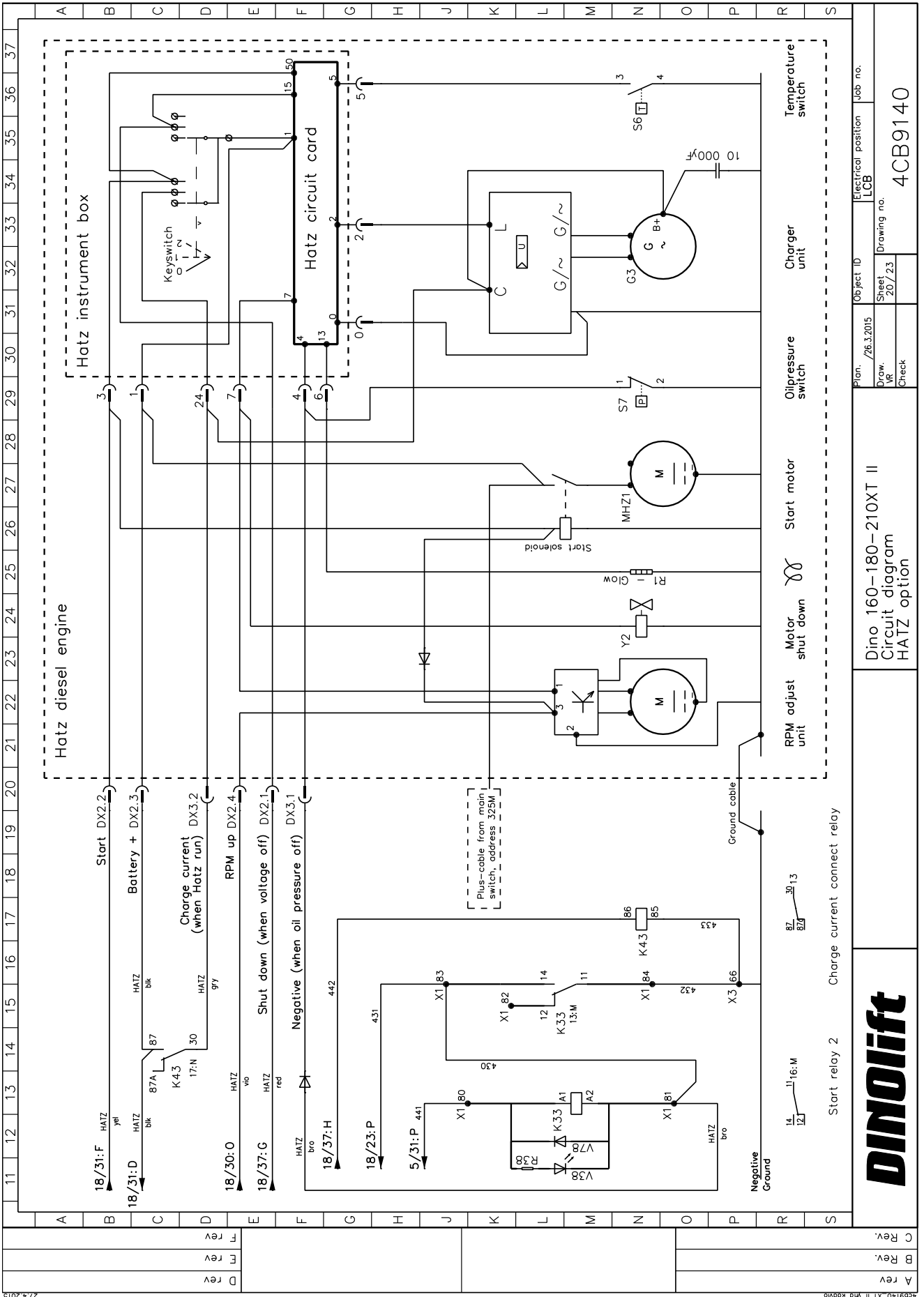

Object ID	Plan	Electrical position	Job no.
26.3.2015	/26.3.2015	LCB	
Sheet	Draw.	Drawing no.	
20/23	VR	4CB9140	
Check			

DINOlift

Dino 160-180-210XT II
Circuit diagram
HATZ option

Start relay 2 Charge current connect relay

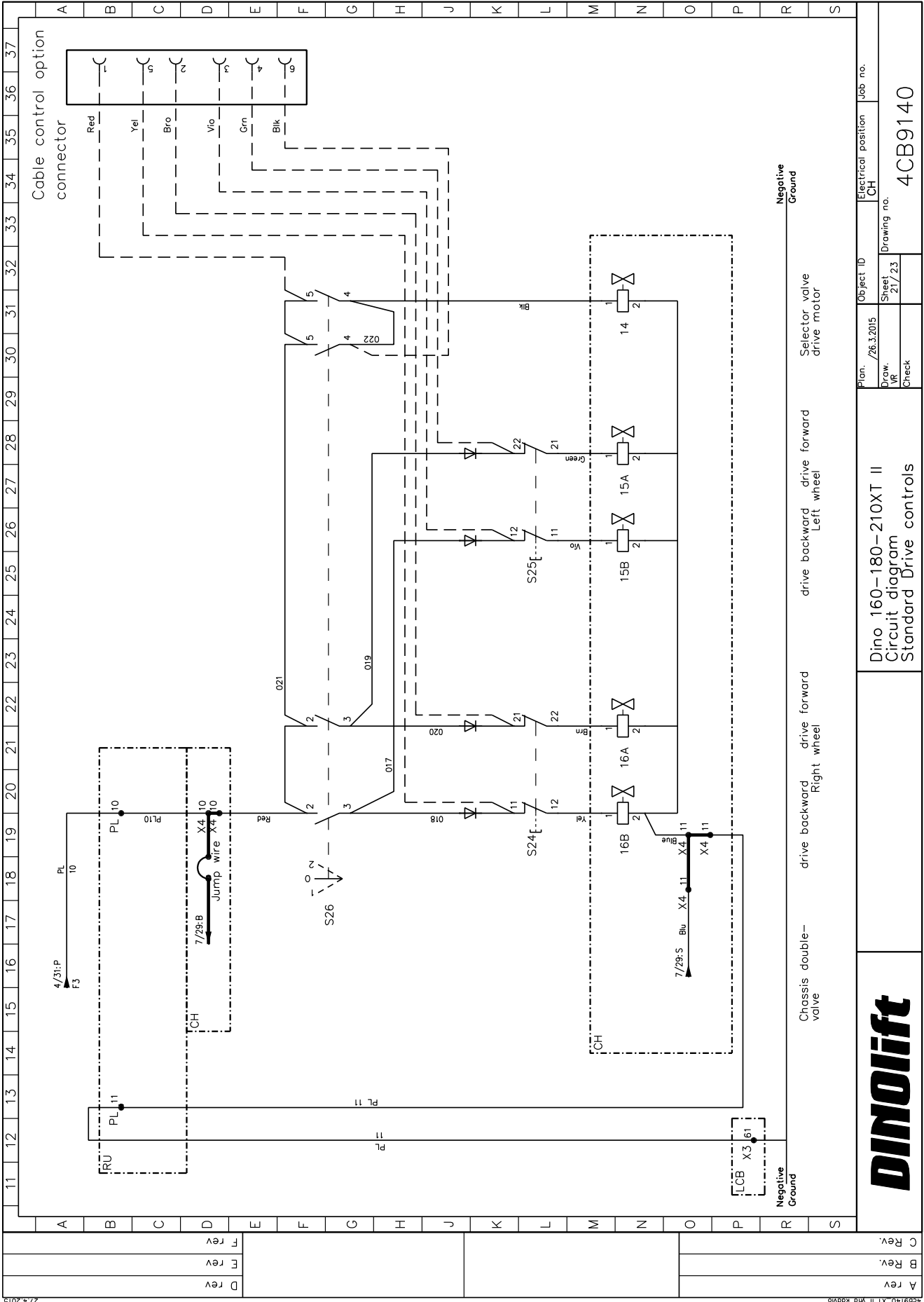

DINOLIFT

Dino 160-180-210XT II
Circuit diagram
Standard Drive controls

Job no.
4CB9140

Plan. /26.3.2015
Object ID

Draw. Vp
Sheet 21/23

Check

Negative Ground

Chassis double-valve

drive backward
drive forward
Right wheel
Left wheel

Selector valve
drive motor

A rev	
B rev	
C rev	
D rev	
E rev	
F rev	

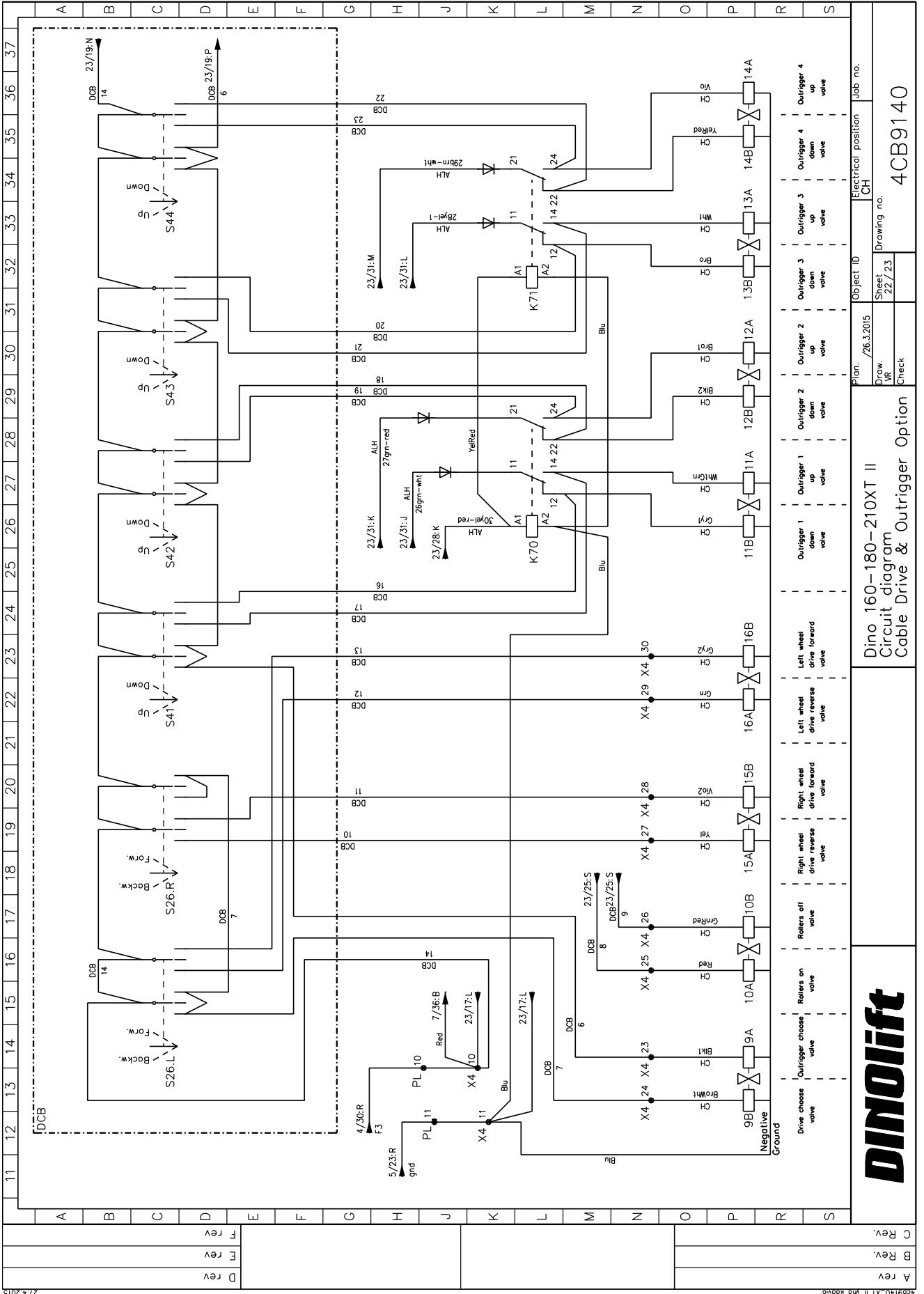

DINOLIFT

Dino 160-180-210XT II
Circuit diagram
Cable Drive & Outrigger Option

Plan: /26.3.2015
Draw: VR
Check
Object ID
Sheet: 22/23
Drawing no.
Electrical position
Job no.
4CB9140

A rev	
B rev	
C rev	

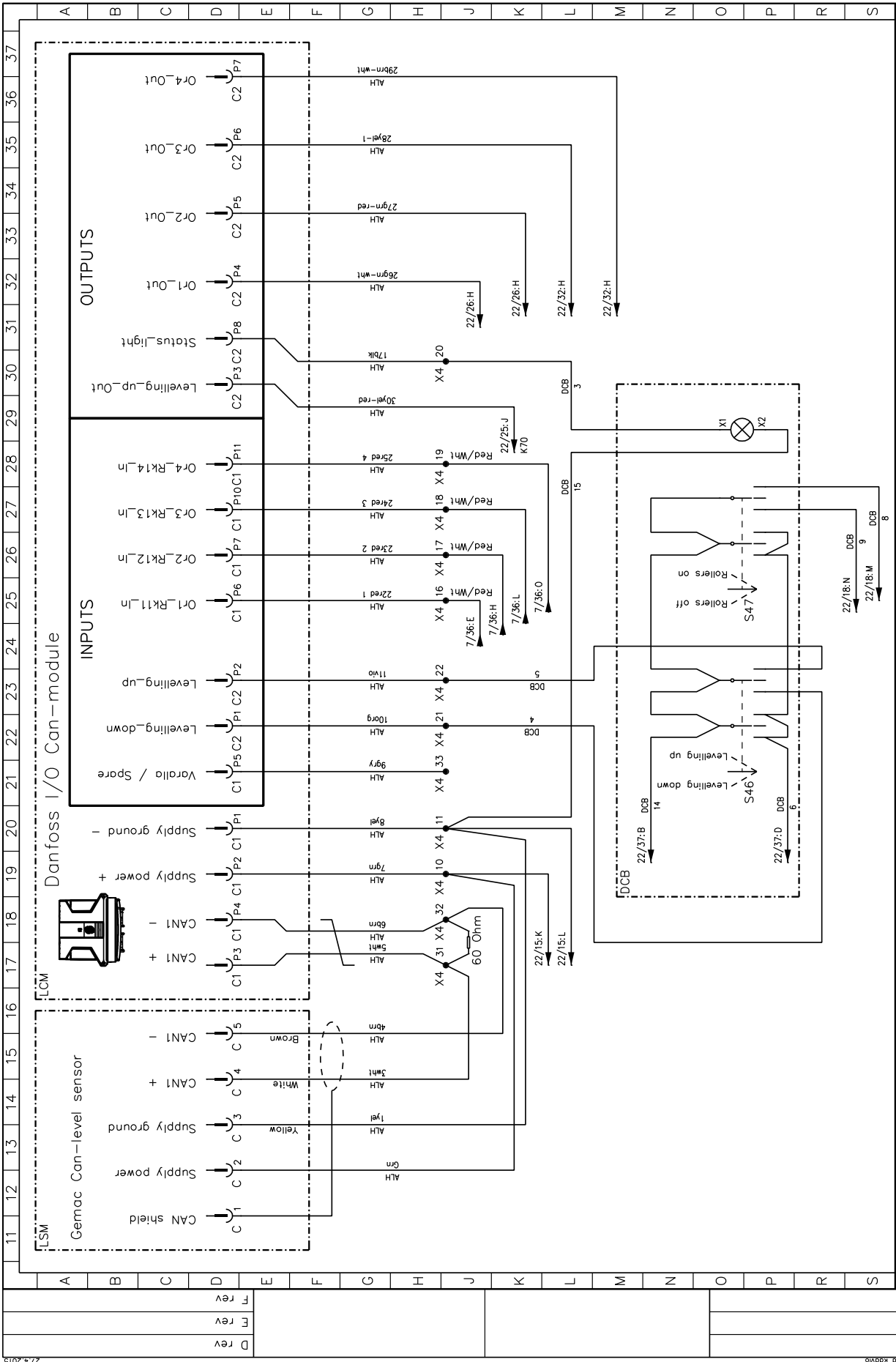

A Rev.	B Rev.	C Rev.	Object ID	Electrical position	Job no.
			Sheet	CH	
D Rev.	E Rev.	F Rev.	Drawn	Drawing no.	4CB9140
			Vf	25/23	
			Plan	/26.3.2015	
			Check		
			Dino 160-180-210XT II Circuit diagram Autolevelling Option		
			DINOLIFT		